



ISSN: 2319-5967

ISO 9001:2008 Certified

International Journal of Engineering Science and Innovative Technology (IJESIT)

Volume 3, Issue 1, January 2014

# A Real Time Embedded Technology for Impairments

S.R.AARTHI AVANTHIGA, DR.V.BALAJI,

*Abstract— In this modern world, the proverb survival of the fittest is not suitable instead I am saying survival of the fastest. It is due to the development of embedded computing technology which is widely used today in many safety-critical applications. Yet there is a need for future scope and development. So researchers have only begun to explore its potential. As more common items corresponding to embedded systems such as washing machines and ATM machine etc incorporate embedded processing capability; the number of such systems could grow exponentially. However, unlike purely digital technologies, embedded systems are limited by more than our imagination. In 2006, Carnegie Mellon University's Priya Narasimhan launched a group effort to develop Trinetra ([www.ece.cmu.edu/~trinetra](http://www.ece.cmu.edu/~trinetra)), a system that lets blind persons self-identify items in a grocery store using a "third eye"—a smart phone and inexpensive off-the-shelf embedded devices. In this scenario, they're also limited by the physical components used to perform its parameter up to the mark—considering their accuracy, size, weight, processing speed, and power requirements etc. Nevertheless, current trends favour the widespread deployment of embedded devices in the future. Human's basic requirement is cultivated eventually. For example Cell phones which permeate society, in processing and communication platform fast approaching ubiquity. And many different market sectors, which start from game developers to the military application, with adequate motivation, create and refine new cognitive aspects, ensuring the availability of adequate R&D resources. One of the many areas in which embedded systems show great promise is gadget technologies, which address the special needs of those with impairments. Hence it's necessary to build a grocery an embedded device. Prototypic sarcastic gadget which is a glove or hand shape material that can recognize basic hand gestures and convert them into speech using low-cost.*

## I. INTRODUCTION

The main aim of the research is to implementing a gadget system for the physically disabled people. The Deaf people have difficulty in communicating with others like who don't understand sign language. In this purpose we are implementing this research. There has been a great development in the past few years on the infusion of technology in the life and curriculum of people with special needs. A technology that enables an individual with a learning disability to compensate for specific deficits is indeed an assistive technology. Technology to incorporate would usually range between the simple low-level technologies to the robust emerging technologies. As technology is meant to help humanity, assistive technology relates well to those with special needs. Research on assistive technology will need to target a variety of people's categories. It will target the subjects with special needs, their parents and families, professionals, policy makers, corporate executives, and the government sector. Successful research will require the cooperation of parental groups, academic institutions, international organizations, non-government organizations, universities, and private centers. The aim of using technology in special needs is to contribute to the possibilities of adoption of assistive technologies in specialized centers or to the preparation for inclusive education. Many researchers will agree that selecting the most appropriate technology for individuals with learning disabilities, requires a careful and systematic plan. It is important to stress that not all assistive technologies are appropriate for all individuals in all situations. People with learning disabilities have their own unique set of strengths, weaknesses, special abilities, interests, and experience. It will become obvious that there is no such "general purpose" assistive technology. Disability requires careful analysis of the interplay between the individual; the specific task/functions to be performed; the specific technology; and the specific contexts of interaction.

A real risk now persists from the flow of the general-purpose assistive technology toys and tools, making it harder for professional to recommend the actual tools due to the very competitive price of the general purpose ones. Each child with special needs is a unique entity with very detailed descriptors that distinguishes him from the others. Only professionals are able to determine those differences and therefore satisfy the need for proper assistance. Robust technologies require the designer to be involved with the world he/she is designing for. The gap between humanities and science needs to be bridged to get the scientists to innovations with human use and nature.



ISSN: 2319-5967

ISO 9001:2008 Certified

International Journal of Engineering Science and Innovative Technology (IJESIT)

Volume 3, Issue 1, January 2014

## II. SIGNIFICANT PROCEDURAL DESIGN

### A. SYSTEM DESIGN

In general, deaf people have difficulty in communicating with others who don't understand sign language. Even those who do speak aloud typically have a "deaf voice" of which they are self-conscious and that can make them reticent. The Hand Talk glove is a normal, cloth driving glove fitted with flex sensors along the length of each finger and the thumb. The sensors output a stream of data that varies with degree of bend. The output from the sensor is analog values it is converted to digital and processed by using microcontroller and then it will be transmitted through wireless communication (RF), then it will be received in the Receiver section and processed using responds in the voice using speaker. In the research Flex Sensor plays the major role, Flex sensors are sensors that change in resistance depending on the amount of bend on the sensor. They convert the change in bend to electrical resistance – the more the bend, the more the resistance value. They are usually in the form of a thin strip from 1"– 5" long that vary in resistance from approximately 10 to 50 kilo ohms. They are often used in gloves to sense finger movement. Flex sensors are analog resistors. They work as variable analog voltage dividers. Inside the flex sensor are carbon resistive elements within a thin flexible substrate. carbon means less resistance. When the substrate is bent the sensor produces a resistance output relative to the bend radius. With a typical flex sensor, a flex of 0 degrees will give 10K resistance with a flex of 90 degrees will give 30-40 K ohms. The bend sensor lists resistance of 30-250 K ohms. In this system we use Radio Frequency Signal to transmit the signal from transmitters to Receptors, in this research we have used microcontroller, a speech IC and also a speaker to produce the output. One of the many areas in which embedded systems show great promise is assistive technologies, which address the special needs of those with impairments. This work presents Hand Talk, a "smart glove" that can recognize basic hand gestures and convert them into speech using low-cost, commercial off-the-shelf (COTS) components. A low-cost, portable gesture-to-speech glove prototype demonstrates that embedded systems don't have to be expensive to be effective.

### B. HARDWARE

As Figure below, design prototypic is built around the following phenomenon

#### Typical transmitter unit

There is an analysis of two different methodologies for describing sarcastic technology as a gadget. The first diagram given below represents one method where the second diagram denotes the second method.

Refer the diagram given below.

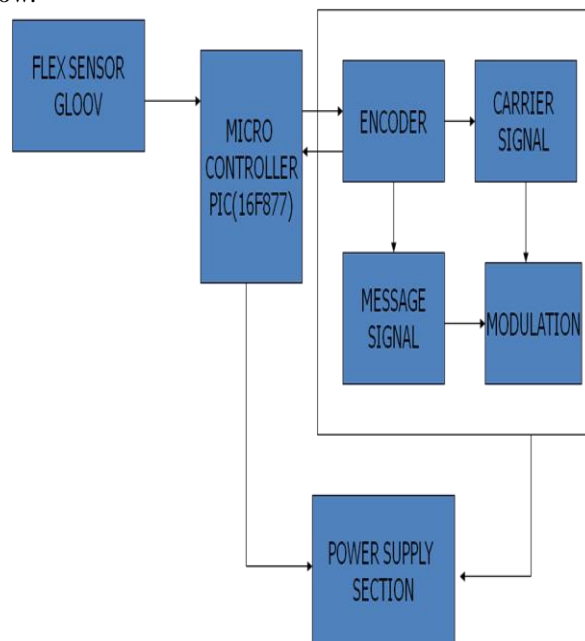

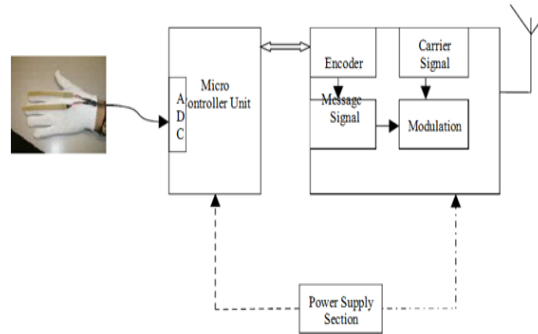

a) A design prototypic architecture for transmitter unit.

Typical receiver unit

Similarly the two methodologies is simultaneously determined for receiver section

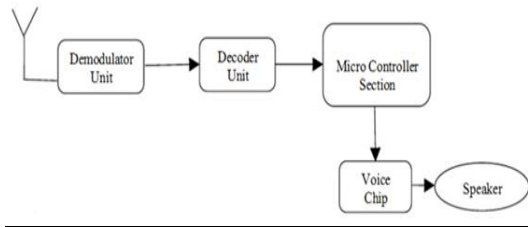

b)A design prototypic architecture for receiver unit

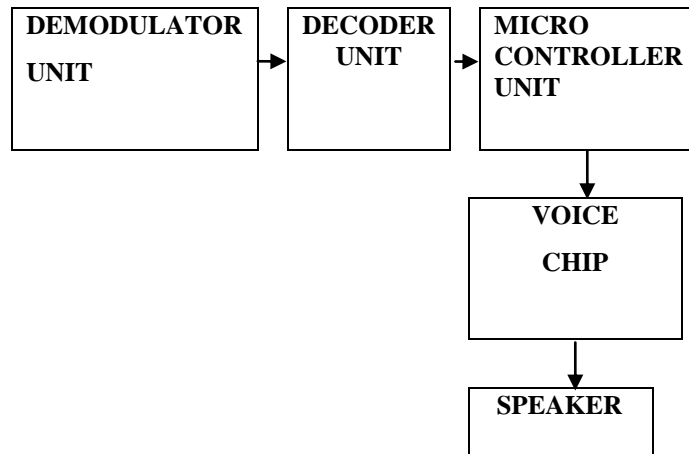

Major hard ware components are associated with the software. Only one component, the flex sensor glove itself, is a design prototypic sarcastic gadget, while the other two—the data microcontroller module and the supply section.. The software includes both embedded applications and embedded c language written in Keil micro vision which runs on and converts sensor data which is a degree of bend into recognized words r the sentence needed for day today life. The design prototypic glove is a normal cloth material glove fitted with flex sensors along the length of each finger and the thumb. The sensors output a stream of data that varies with degree of bend. The degree of bend is an analog signal which is converted in to digital form of pattern. Capturing the data provided by the flex sensors, quantizes it, and wirelessly streams it via a receiver which contains a loud speaker. Hence would be equally capable of running the system. The design prototypic sensor converts the quantized data into text via microcontroller and the coding language, herewith which is predefined. Modulation therefore determines the two different types of signal which is carrier signal and message signal. Step one was attaching the flex sensors to the glove r hand type material. LM258/LM358 op-amps which is defined for a flex sensor as shown.

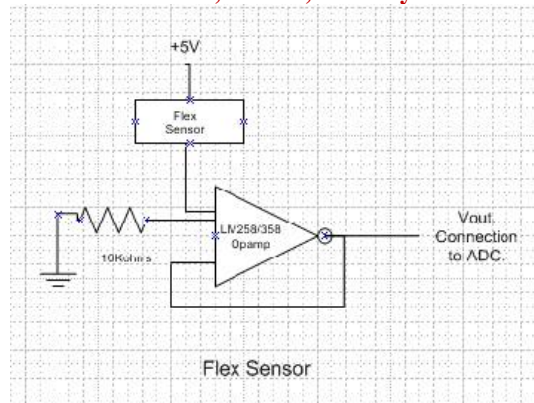

c) Flex sensor connected to LM258/LM358 op- amps

The research therefore fitted the design prototypic glove with only one sensor, for a total of five sensors. This limitation placed obvious constraints on what the glove could achieve, especially considering complexity and variations among individual users in performing the signs. However, felt that five sensors would be adequate to recognize a simplified set of signs. The sensors were fastened to the glove using basic attachment technology. They require a 5-volt input and output between 0 and 5 V, the resistivity varying with the sensor's degree of bend and the voltage output changing accordingly. The sensors connect to the Pic microcontroller which has the ability of converting analog signal to digital pattern. Sentry device via three pin connectors (ground, live, and output). The device can activate the sensors from sleep mode, enabling them to power down when not in use and greatly decreasing power. Model example representation is shown below



d) Sensor attachment to the glove

The degree of bend determines the predefined aspects of a word or a sentence similar to sign languages. The performance of the bend is shown below.



ISSN: 2319-5967

ISO 9001:2008 Certified

International Journal of Engineering Science and Innovative Technology (IJESIT)

Volume 3, Issue 1, January 2014



e) Performance of degree of bend

### C. SOFTWARE

#### *Concept of compiler*

Compilers are programs used to convert a High Level Language to object code. Desktop compilers produce an output object code for the underlying microprocessor, but not for other microprocessors. I.E the programs written in one of the HLL like 'C' will compile the code to run on the system for a particular processor like x86 (underlying microprocessor in the computer). For example compilers for Dos platform is different from the Compilers for UNIX platform So if one wants to define a compiler then compiler is a program that translates source code into object code. The compiler derives its name from the way it works, looking at the entire piece of source code and collecting and reorganizing the instruction. See there is a bit little difference between compiler and an interpreter. Interpreter just interprets whole program at a time while compiler analyzes and execute each line of source code in succession, without looking at the entire program. The advantage of interpreters is that they can execute a program immediately. Secondly programs produced by compilers run much faster than the same programs executed by an interpreter. However compilers require some time before an executable program emerges. Now as compilers translate source code into object code, which is unique for each type of computer, many compilers are available for the same language.

#### *Concept of cross compiler*

A cross compiler is similar to the compilers but we write a program for the target processor (like 8051 and its derivatives) on the host processors (like computer of x86)It means being in one environment you are writing a code for another environment is called cross development. And the compiler used for cross development is called cross compiler So the definition of cross compiler is a compiler that runs on one computer but produces object code for a different type of computer. Cross compilers are used to generate software that can run on computers with a new architecture or on special-purpose devices that cannot host their own compilers. Cross compilers are very popular for embedded development, where the target probably couldn't run a compiler. Typically an embedded platform has restricted RAM, no hard disk, and limited I/O capability. Code can be edited and compiled on a fast host machine (such as a PC or UNIX workstation) and the resulting executable code can then be downloaded to the target to be tested. Cross compilers are beneficial whenever the host machine has more resources (memory, disk, I/O etc) than the target. Keil C Compiler is one such compiler that supports a huge number of host and target combinations. It supports as a target to 8 bit microcontrollers like Atmel and Motorola etc.





ISSN: 2319-5967

ISO 9001:2008 Certified

International Journal of Engineering Science and Innovative Technology (IJESIT)

Volume 3, Issue 1, January 2014

### *Why do we need cross compiler?*

There are several advantages of using cross compiler. Some of them are described as follows

- By using this compilers not only can development of complex embedded systems be completed in a fraction of the time, but reliability is improved, and maintenance is easy.
- Knowledge of the processor instruction set is not required.
- A rudimentary knowledge of the 8051's memory architecture is desirable but not necessary.
- Register allocation and addressing mode details are managed by the compiler.
- The ability to combine variable selection with specific operations improves program readability.
- Keywords and operational functions that more nearly resemble the human thought process can be used.
- Program development and debugging times are dramatically reduced when compared to assembly language programming.
- The library files that are supplied provide many standard routines (such as formatted output, data conversions, and floating-point arithmetic) that may be incorporated into your application.
- Existing routine can be reused in new programs by utilizing the modular programming techniques available with C.
- The C language is very portable and very popular. C compilers are available for almost all target systems. Existing software investments can be quickly and easily converted from or adapted to other processors or environments.

Now after going through the concept of compiler and cross compilers lets we start with Keil C cross compiler.

### *Keil C cross compiler*

Keil is a German based Software development company. It provides several development tools like • IDE (Integrated Development environment)

- Research Manager
- Simulator
- Debugger
- C Cross Compiler, Cross Assembler, Locator/Linker

Keil Software provides you with software development tools for the 8051 family of microcontrollers. With these tools, you can generate embedded applications for the multitude of 8051 derivatives. Keil provides following tools for 8051 development

1. C51 Optimizing C Cross Compiler,
2. A51 Macro Assembler,
3. 8051 Utilities (linker, object file converter, library manager),
4. Source-Level Debugger/Simulator,
5.  $\mu$ Vision for Windows Integrated Development Environment.

The keil 8051 tool kit includes three main tools, assembler, compiler and linker. An assembler is used to assemble your 8051 assembly program



ISSN: 2319-5967

ISO 9001:2008 Certified

International Journal of Engineering Science and Innovative Technology (IJESIT)

Volume 3, Issue 1, January 2014

A compiler is used to compile your C source code into an object file A linker is used to create an absolute object module suitable for your in-circuit emulator.

**8051 research development cycle:** These are the steps to develop 8051 research using keil

1. Create source files in C or assembly.
2. Compile or assemble source files.
3. Correct errors in source files.
4. Link object files from compiler and assembler.
5. Test linked application.

Now let us start how to work with keil. Keil is a cross compiler. So first we have to understand the concept of compilers and cross compilers. After then we shall learn how to work with keil. The representation of flow chart is shown below.

### III. FLOW DIAGRAM

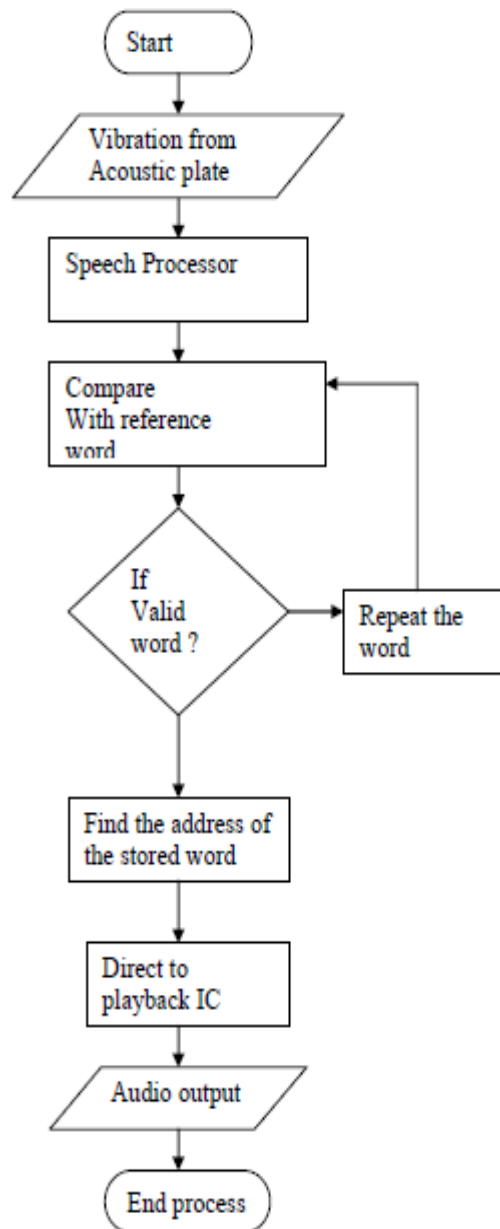



ISSN: 2319-5967

ISO 9001:2008 Certified

International Journal of Engineering Science and Innovative Technology (IJESIT)

Volume 3, Issue 1, January 2014

#### IV. TOOLS USED

CONTROLLER:

8051

PIC

COMPILER

KEIL IDE

MPLAB IDE

#### V. CONCLUSION

The assistive aid that was developed resulted in providing an user friendly approach to the speech impaired people. The user dependent system provided 90 percent accuracy. This system helps the speech impaired people and for the bed-ridden deaf and dumb people to express their need and announce their requirements. As per the experimental results, we developed this proposed concept and thus it is practically possible. Thus this system will help the physically challenged people to a greater extent and also improves the sophistication in driving. MEMS (Micro Electro Mechanical System) are system which are similar to conventional electromechanical systems but are built in the size of a few microns. They can perform the function of electromechanical systems like motion or acceleration detection. The added advantage with MEMS is that the size of such systems is very compact and hence can be used for a lot of applications which are otherwise not possible. This research aims at using a MEMS based device for developing assistance system for the physically challenged people who are partially paralyzed or cannot walk and are restricted to a bed and are also unable to speak. In this research a system is built which will enable them to control the most frequently required things which could be devices like the lighting in the room or other electrical devices. Also, a voice processor is used in which programmed voice response can be stored. This research helps the motion-impaired people, who cannot move from one place to another on their own, by enabling them to control the most frequently required things. This could be the control of electrical devices such as, switching ON/OFF the lights and fan in the room. Also the voice processor helps the dumb by producing voice response when the patient is in need of say, food or emergency. All this can be achieved using a MEMS sensor, whose positional changes are detected, resulting in the performance of the functions in need. This reduces the dependency of the physically challenged people on others, thereby empowering them and making them independent for meeting their basic needs. The instrument is of low cost and affordable. It is easily controlled to patients. Embedded systems don't have to be expensive to be effective. With its small research team and almost no budget, the Hand Talk project illustrates the creative possibilities for innovative developers using inexpensive COTS components. Work continues on the system. The next version of the glove will have between 20 and 30 separate Sensors, including pressure sensors and accelerometers. To support this increase, the CMU team plans to replace the Blue Sentry device with a custom board having an adequate number of inputs. If possible, they'll also build data segmentation into the hardware to remove part of the processing load from the phone. Major improvements in sign recognition Algorithms are also on the horizon.

The future scope of the proposed concept is the use of MEMS technology for voice recognition to control the car. Micro-Electro-Mechanical Systems consists of mechanical elements, sensors, actuators, and electrical and electronics devices on a common silicon substrate. The sensors in MEMS gather information from the environment through measuring mechanical, thermal, biological, chemical, optical, and magnetic phenomena. The electronics then process the information derived from the sensors and through some decision making capability direct the actuators to respond by moving, positioning, regulating, pumping, and filtering, thereby controlling the environment for some desired outcome or purpose.

#### REFERENCES

- [1] Dr Wald, M., "The role of assistive technologies in supporting student learning", Southern Higher and Further Education Collaboration, University of Southampton, Chapter 5, July 2002.
- [2] Antzakas, K. & Woll, B., "Hand Movements and Negation in Greek Sign Language", Gesture Workshop, City University of London, 2001, 193--196.





ISSN: 2319-5967

ISO 9001:2008 Certified

**International Journal of Engineering Science and Innovative Technology (IJESIT)**

**Volume 3, Issue 1, January 2014**

- [3] Lampropoulou, V., "Meeting the needs of deaf children in Greece. A systematic approach", Journal of the British Association of Teachers of the Deaf.
- [4] Kubin G. Nonlinear Processing of Speech, in Speech Coding and Synthesis [M]. Elsevier Science B.V., 1995, pp.557-610. Microchip For PIC Micro controller.
- [5] N.P.Bhatti, A. Baqui, B.S.Chowdhry, M.A.Unar,"Electronic Hand Glove for Speech Impaired and Paralyzed Patients", EIR Magazine, May 2009, pp.59-63, Karachi, Pakistan.
- [6] Murry, F. R., & Murry, G. B. (2000). Using a lesson template to integrate general and special education: Teaching lesson template use to educators of students with special needs. In: Annual Proceedings of the National Convention of the Association for Educational Communications. Information & Technology (1-2).
- [7] Reimer-Reiss M, Wacker R 2000 Factors Associated with Assistive Technology Discontinuance Among Individuals with Disabilities, Journal of Rehabilitation, Jul-Sept 2000 .
- [8] Roland-Mieszkowski, M.Sc., Ph.D., and Andrzej Czyzewski, Ph.D. and Bozena Kostek, " The Digital Speech Aid", Halifax, Nova Scotia, Canada, Proceedings of the Congress, Dec 1993.
- [9] Ronald J. Seiler (2007), Assistive Technology for Individuals with Cognitive Impairments, The Idaho Assistive Technology Research, Center on Disabilities and Human Development, University of Idaho, Moscow, December 2007.
- [10] Schreier, E.M.\*, Levanthal, D.D., Uslan, M.M. (1991). Access technology for blind and visually impaired persons. Technology and Disability, 1 (1), 19-23.
- [11] Accessibility technology', Wikipedia online encyclopedia, Retrieved on 10th January, 2012 from <http://en.wikipedia.org/wiki/Accessibility>'The Microsoft Researches on Speech Processing' Retrieved on 18th February, 2012 from <http://research.microsoft.com/enus/roups/srg>"Bio MEMS: revolutionizing medicine and healthcare," In Stat/MDR, Scottsdale, AZ, 2002.
- [12] Brewster SA, Raty VP, Kortekangas A. Enhancing scanning input with non-speech sounds. In ACM conference on Assistive technologies (ASSET'96); 1996, p 10 — 14.
- [13] Duhaney, L. M., & Duhaney, D. C. (2000). Assistive technology: Meeting the needs of learners with disabilities. International Journal of Instructional Media, 27(4), 393-402.
- [14] Dunn, Michael (2007) Give Applications a Voice, Speech synthesis and recognition in .NET, Tech Brief Articles, Retrieved on 14th March, 2012.
- [15] [http://reddevnews.com/articles/2007/02/15/give-applications-avoice.aspx?sc\\_lang=en](http://reddevnews.com/articles/2007/02/15/give-applications-avoice.aspx?sc_lang=en) Mirenda, P. (2001). Autism, augmentative communication, and assistive technology: What do we really know? Focus on Autism & Other Developmental disabilities, 16(3), 141-152.
- [16] Mukherjee A, Bhattacharya S, Chakraborty K, Basu A. Breaking the accessibility barrier: Development of special computer access mechanisms for the neuromotor disabled in India In International Conference on Human Machine Interfaces; 2004 (IC'Hi1fl: p 136—141.
- [17] Volicer L, Harper D G, Manning B C et al 2001 Sun downing and circadian rhythms in Alzheimer's disease. American Journal of Psychiatry 158(5):704-711.