



ISSN: 2319-5967

ISO 9001:2008 Certified

International Journal of Engineering Science and Innovative Technology (IJESIT)

Volume 2, Issue 3, May 2013

# Design and Implementation of ECG Monitoring and Heart Rate Measurement System

Naazneen M. G., Sumaya Fathima, Syeda Husna Mohammadi, Sarah Iram L. Indikar,  
Abdul Saleem, Mohamed Jebran

Department of Electronics & Communication Engineering, HKBKCE, VTU, Belgaum

*Abstract— This paper describes the design of a simple 3-lead Electrocardiogram (ECG) monitoring and heart rate measurement system with LCD output. The system takes the physical pulse input using Ag/Cl sticking electrodes stuck to the arms and right leg of the patient under observation. The model encompasses of instrumentation amplifier and filter circuits etc, which are used for signal conditioning of the pulse input from the patient's body and displayed on CRO as the ECG waveform. Thus conditioned signal is also processed by the microcontroller AT89S52 to count the heart for duration of one minute and displays the information on LCD display.*

*Index Terms— Electrocardiogram (ECG), Electrodes, Heart Rate, Patient.*

## I. INTRODUCTION

Nowadays, the volume of Electrocardiogram (ECG) recorded in hospitals is increasing as the people suffering from heart diseases are increasing at an alarming rate. The ECG is one of the medical equipment that can measure the heart rate, convert it into a signal and present the data on a piece of paper or on a monitor. An ECG is a recording of the electrical activity on the body surface generated by the heart. ECG measurement information is collected by electrodes placed at designated locations on the body. It is the best way to measure and diagnose abnormal rhythms of the heart [1], particularly abnormal rhythms caused by damage to the conductive tissue that carries electrical signals, or abnormal rhythms caused by electrolyte imbalances [2]. In a Myocardial infarction (MI), the ECG can identify if the heart muscle has been damaged in specific areas, though not all areas of the heart are covered [3]. The ECG cannot reliably measure the pumping ability of the heart, for which ultrasound-based (echocardiography) or nuclear medicine tests are used. It is possible to be in cardiac arrest with a normal ECG signal (a condition known as pulse less electrical activity).

Electro-cardiogram (ECG) is [4] one of frequently used and accurate methods for measuring the heart rate. ECG is an expensive device and its use for the measurement of the heart rate only is not economical. Low-cost devices in the form of wrist watches [5, 6] are also available for the instantaneous measurement of the heart rate. Such devices can give accurate measurements but their cost is usually in excess of several hundred dollars, making them uneconomical. Most hospitals and clinics in the UK use integrated devices designed to measure the heart rate, blood pressure, and temperature of the subject. Although such devices are useful, their cost is usually high and beyond the reach of individuals. This paper describes the design of an ECG monitoring system which monitors ECG and heart rate measurement system which measures the heart rate of the subject by Ag / Cl sticking electrode on the arms and then displaying the ECG on cathode ray oscilloscope (CRO) and heart rate on a text based LCD. The device has the advantage that it is microcontroller based and thus can be programmed to display various quantities, such as the normal, maximum and minimum rates over a period of time and so on. Another advantage of such a design is that it can be expanded and can easily be connected to a recording device or a PC to collect and analyze the data for over a period of time.

## II. SYSTEM ARCHITECTURE

Figure 1 shows the block diagram of the proposed system. Basically, the system consists of an Ag / Cl sticking electrode or a sensor,. The second stage is an Instrumentation amplifier (IA), which has a high gain (1000) .The output of IA, is passed through the low pass filter with a cut off frequency of 150Hz. The amplifier block is used to saturate the ECG signals to obtain square waveform. Cathode Ray Oscilloscope (CRO) is used to display the ECG. Microcontroller is used to perform the counting of pulses. LCD is used to display the heart rate.

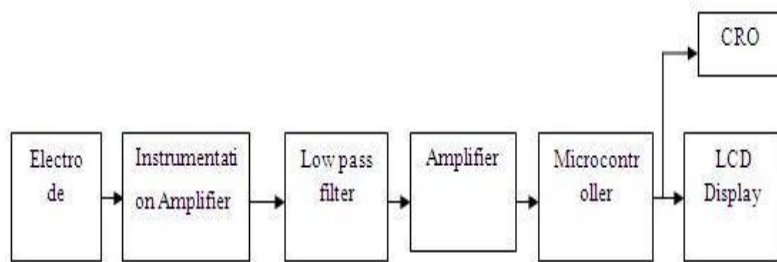

Fig 1: Block diagram of the ECG measuring and heart rate measurement system [11]

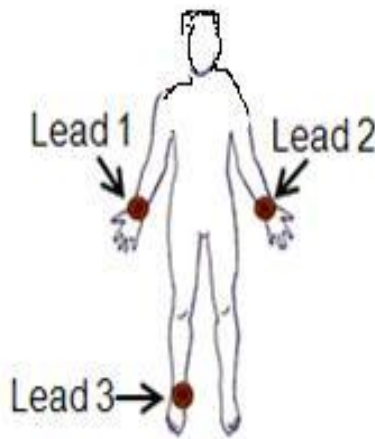

Fig 2: A 3-lead connection. [22]

**A. Electrode:**

It converts physical signals into electrical voltage. The voltage is in the range of 1 mV ~ 5 mV. The sensor pair is stuck on the right arm (RA), left arm (LA) and right leg (RL) of the subject (see Figure 2).

**Wilson Electrode System:** In our project we have used Wilson Electrode system. This system uses the right leg of the patient as “driven right leg lead”. This involves a summing network to obtain the sum of the voltages from all other electrodes and driving amplifier, the output of which is connected to the right leg of the patient. This arrangement is known as Wilson electrode system. The effect of this arrangement is to force the reference connection at the right leg of the patient to assume a voltage level equal to the sum of the voltages at the other leads. This arrangement increases the common mode rejection ratio of the overall system and reduces noise interference. It also has the effect of reducing the current flow in to the right leg electrode.

**B. Instrumentation Amplifier:**

Many industrial and medical applications use instrumentation amplifiers (INAs) to condition small signals in the presence of large common-mode voltages and DC potentials so we choose Analog instrumentation amplifier to amplify the ECG voltage from electrodes, which is in the range of 1mV to 5mV. we have designed the instrumentation amplifier using op-amp 741, with a gain of 1000 and power supply is +12V to -12V.

**C. Low pass filter:**

This block is used to remove the unwanted signals like noise, the frequency range of ECG is 0.04HZ to 150 Hz, and so the low pass filter is designed with the cut off frequency of 150HZ.

**D. Amplifier:**

It consists of a simple non inverting amplifier which is designed to saturate the ECG signals, and the output of amplifier is fed to the microcontroller to count the heart rate.

**E. Microcontroller:**

Microcontroller AT89S52 is being used in our project for counting of the pulses. It takes the conditioned square pulses from hardware system as an input and counts it for one minute, which is the required heart rate count.

**F. LCD:**

It is used to displaying the result on a text based LCD (Normal, Low, High).

III. DESIGN OF THE SYSTEM

In this section we have defined briefly the hardware implementation of the system. The hardware implementation part describes briefly the ECG monitoring circuit system parts such as electrodes, instrumentation amplifier, low pass filter and non-inverting amplifier. The Figure 3 depicts the circuit diagram of the ECG monitoring and Heart rate measurement system.

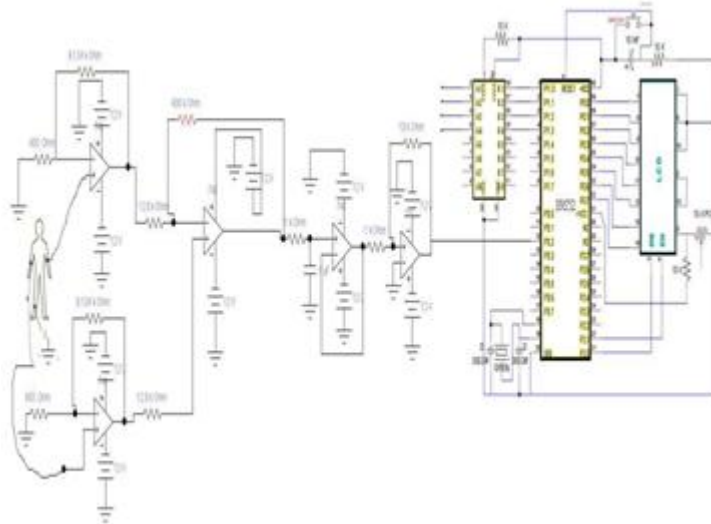

Fig 3: Designed Circuit diagram of the system

A. Design of Instrumentation Amplifier

An instrumentation amplifier is usually the very first stage in an instrumentation system. This is because of the very small voltages usually received from the probes need to be amplified significantly to be proceeding stages. An instrumentation amplifier (IA) is a difference amplifier where the difference between the two input terminals is amplified and the common signals between the inputs are rejected (Common Mode Rejection (CMR)). The latter function is the device characteristic, termed the Common Rejection Ratio (CMRR). As depicted in Figure 4, it typically consists of three op-amps [7].

Although the instrumentation amplifier is usually shown schematically identical to a standard op-amp, the electronic instrumentation amp is almost always internally composed of 3 op-amps [13]. These are arranged so that there is one op-amp to buffer each input (+, -), and one to produce the desired output with adequate impedance matching for the function. The most commonly used instrumentation amplifier circuit is shown in the figure 4. The gain of the circuit is [7].

$$V_{out} / V_2 - V_1 = (1 + 2R_2/R_1) R_4/R_3 \quad (1)$$

The rightmost amplifier, along with the resistors labeled  $R_3$  and  $R_4$  is just the standard differential amplifier circuit, with gain =  $R_4 / R_3$  and differential input resistance =  $2 \cdot R_3$ . The two amplifiers on the left are the buffers. With  $R_1$  removed (open circuited), they are simple unity gain buffers; the circuit will work in that state, with gain simply equal to  $R_4 / R_3$  and high input impedance because of the buffers. The buffer gain could be increased by putting resistors between the buffer inverting inputs and ground to shunt away some of the negative feedback; however, the single resistor  $R_2$  between the two inverting inputs is a much more elegant method: it increases the differential-mode gain of the buffer pair while leaving the common-mode gain equal to 1. This increases the common-mode rejection ratio (CMRR)[7,11] of the circuit and also enables the buffers to handle much larger common-mode signals without clipping than would be the case if they were separate and had the same gain. Another benefit of the method is that it boosts the gain using a single resistor rather than a pair, thus avoiding a resistor-matching problem (although the two  $R_2$ s need to be matched), and very conveniently allowing the gain of the circuit to be changed by changing the value of a single resistor. A set of switch-selectable resistors or even a potentiometer can be used for  $R_1$ , providing easy changes to the gain of the circuit, without the complexity of having to switch matched pairs of resistors.

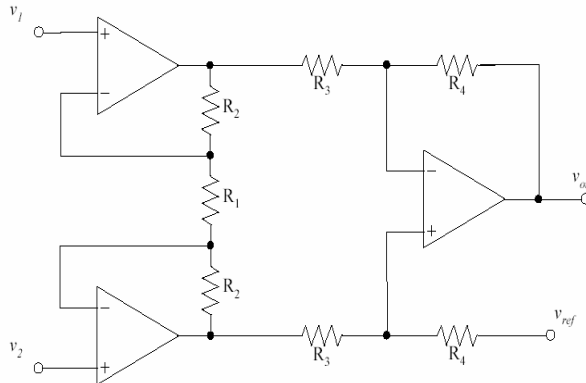

Fig 4: Three Op-amp instrumentation amplifier [11]

*Design:*

Given  $A_v = 1000$ , Supply voltage =  $\pm 12V$

Stage 1:  $A_{v1} = A_{v2} = A = 1000 = 31.62$

$$I_2 = 100 I_B (\text{max}) = 50 \mu A$$

$$R_2 = V_i / I_2 = 20 \text{mA} / 50 \mu A$$

$$A_{v(\text{DIFF})} = 2R_1 + R_2 / R_2$$

$$R_1 = R_2 / 2[A_{v(\text{diff})} - 1] = 400 / 2 [31.62 - 1]$$

$$R_3 = R_1 = 6.12 \text{k}\Omega$$

Stage 2:  $V_0 = A_v V_i = 1000 * 20 \text{mV} = 20V$

$$I_5 = 100 I_B (\text{max}) = 50 \mu A$$

$$R_5 = V_0 / I_5 = 20 \text{mV} / 50 \mu A = 400 \text{k}\Omega$$

$$R_4 = R_5 / A_{v2} = 400 \text{k}\Omega / 31.62 = 12.65 \text{k}\Omega$$

$$R_6 = R_4 = 12.65 \text{k}\Omega$$

$$R_7 = R_5 \pm 20\% = 400 \text{k}\Omega \pm 20\%$$

*B. Design of Low pass filter*

The general expression of a low pass filter is:

$$f_c = 1 / (2\pi RC)$$

Or equivalently (in radians per second)

$$\omega_c = 1 / RC$$

The figure 5 depicts a design of low pass filter in our system

*Design:*

The low pass active filter has designed for a cut-off frequency of 150Hz.

Let  $f_c$  be the cut off frequency

$$f_c = 1 / (2\pi RC)$$

Given  $f_c = 150 \text{Hz}$

Where  $C = 1 \mu\text{f}$ , So R value can be calculated as

$$R = 1 / (2 * \pi * C * 150)$$

$$= 1 / (2 * \pi * 1 \mu\text{f} * 150)$$

$$= 1 \text{k}\Omega$$

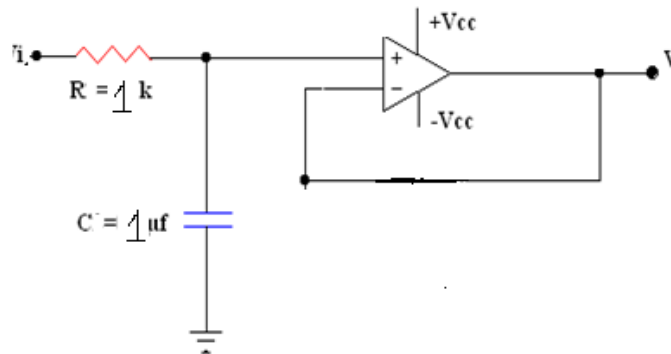

Fig 5: First order low pass filter [7]

**A. Non-Inverting amplifier design**

The amplitude of the ECG signal decreases because of the active filter. So the ECG signal has to be amplified so that it can be transferred to the next stage. The main goal of designing a non-inverting amplifier is to saturate the all ECG signals and convert them into square waveforms and these square pulses are used as an input to AT89S52 microcontroller. [8, 9, 11, 19]

The design of amplifier is Gain is given by,

$$\text{Gain} = A_v = 1 + R_F / R_1$$

Let  $R_1 = 1K\Omega$ ,  $R_F = 10k\Omega$  so we will get gain  $A_v$  as

$$A_v = 1 + R_F / R_1$$

$$A_v = 1 + 10k / 1k$$

$$A_v = 11$$

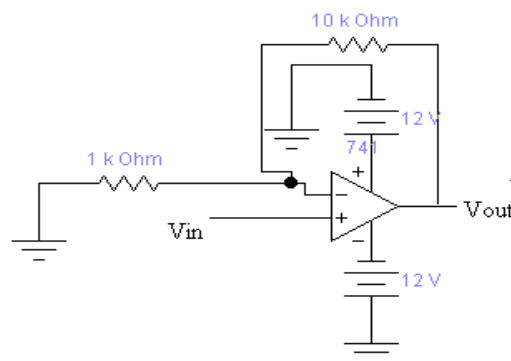

Fig 6: Designed non-inverting amplifier

**IV. THE SOFTWARE SYSTEM**

**A. Keil uVision3 Software:**

The software was developed using the Keil  $\mu$ Vision 3 Software. It compiles C code, assembles assembly source files, link and locate object modules and libraries, creates HEX files, and debugs the target program. Vision is an integrated development environment that combines project management, source code editing, and program debugging in one single, powerful environment. The CX51 ANSI optimizing C Cross-Compiler creates relocatable object modules from the C source code. [8,9]

*SPI Flash Programmer Version 3.7:* This SPI Flash Programmer can be used either for in-system programming or as a stand-alone serial flash programmer for the Atmel SPI programmable devices. The programmer hardware interface is controlled by the PC parallel port and the parallel port control signals are freely selectable by the user. The software supports both the 8051 and AVR series devices. [23]

**B. Flow chart of the program:**

The program is written in assembly C language. Figure 7 depicts a flow chart to measure the heart rate.

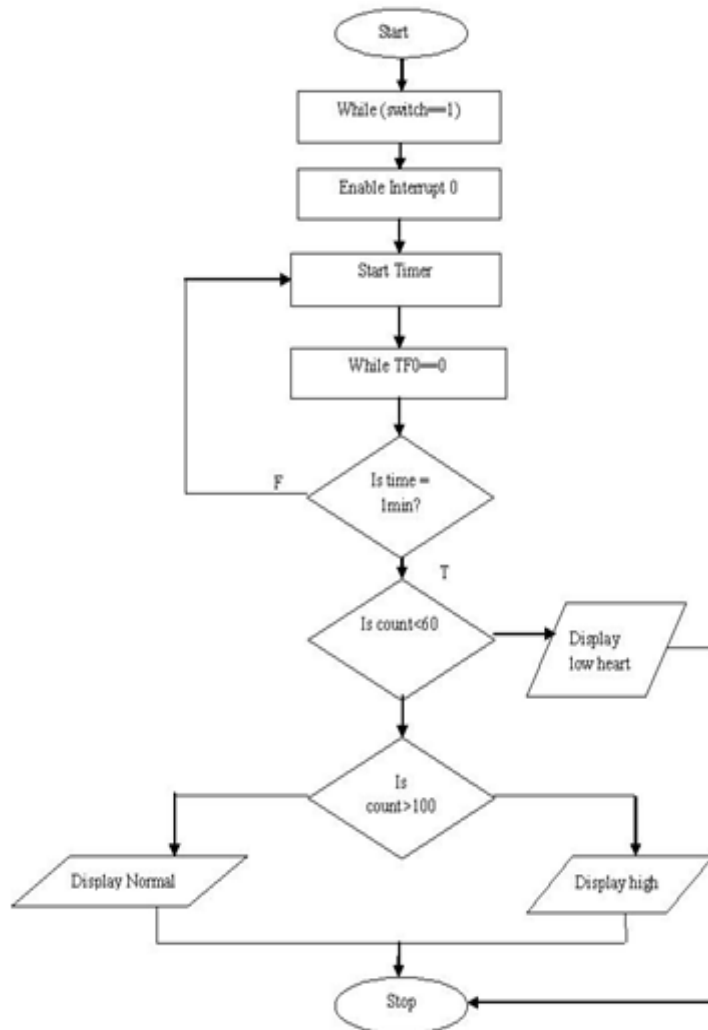

**Fig 7: Flow chart to count heart rate**

At the beginning of the program various variables used in the program are declared and PORT 3.2 pin is configured as input port. The program waits until the switch is pressed. Then, the external interrupt is enabled and the heart rate is counted for duration of one minute and displayed on the LCD.

## V. RESULTS

At the initial stage, the output of the instrumentation amplifier was not found proper as a result we have not found required gain value at the output of Instrumentation amplifier circuit, hence we simulated the instrumentation amplifier circuit in electronics work bench and got the wave form with a gain of 1000. The output waveform of the instrument amplifier circuit in electronics work bench software can be depicted by using the figure 9 and figure 8 depicts the design of instrumentation amplifier in electronic work bench software.

### A. Implementation Results:

The initial circuit of hardware of our system is instrumentation amplifier. The results of simulation of instrumentation amplifier using Electronic Work Bench Software helped us to choose the component values to be Implemented on the bread board. We could get the required output waveform, which was displayed on CRO successfully. The figure 10 depicts the instrumentation amplifier output.



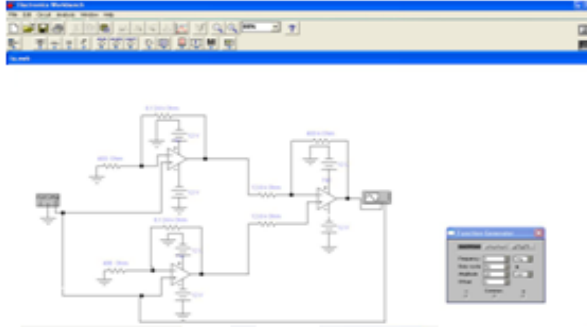

Fig 8: Instrumentation amplifier circuit design for a gain of 1000 in EWB

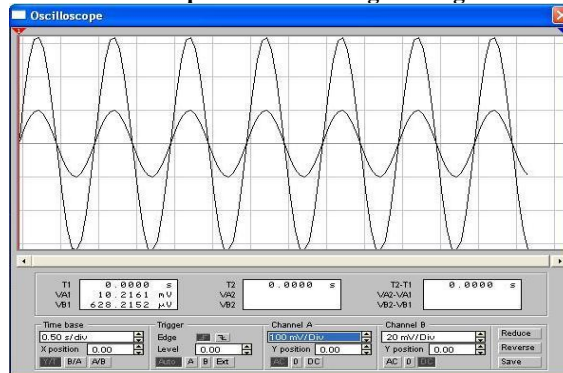

Fig 9: Output of IA in Electronic work bench software

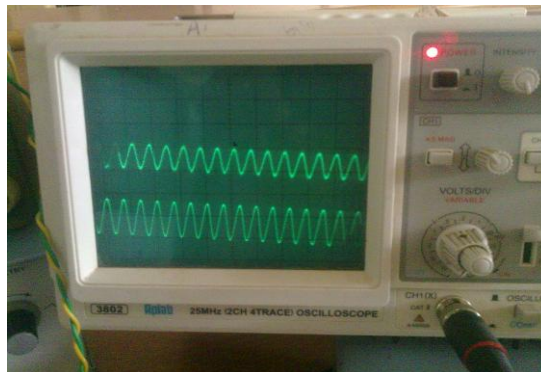

Fig 10: Instrumentation Amplifier circuit output on CRO  
The complete hardware setup is as shown in figure 11.

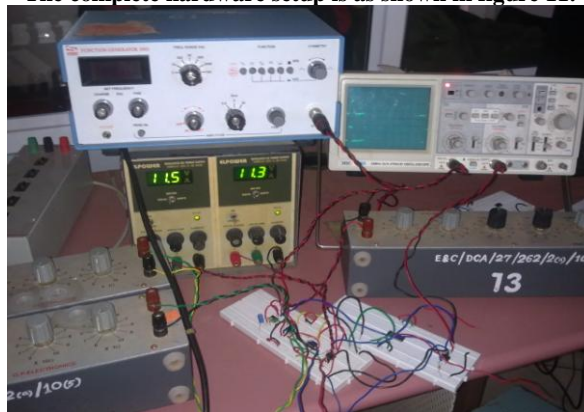

Fig 11: ECG experimental set up on bread board



ISSN: 2319-5967

ISO 9001:2008 Certified

International Journal of Engineering Science and Innovative Technology (IJESIT)

Volume 2, Issue 3, May 2013

We could get the display of ECG waveform on CRO through electronic hardware implementation of our project successfully. This can be seen by Figure 12, which shows an ECG signal acquired by the electrode on a CRO. Noise was reduced through implementation of a ground plane. Filtering technique attenuated unwanted noise to highlight the electrocardiogram signal.

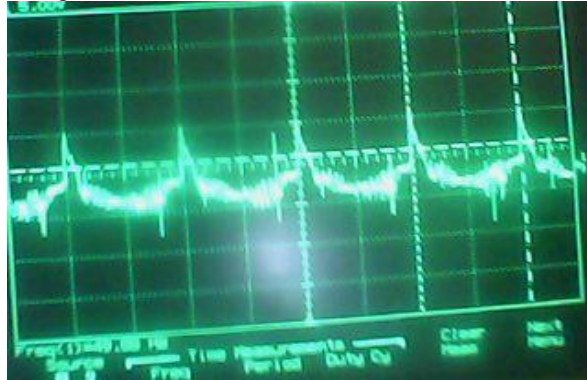

Fig 12: ECG waveform on CRO

In the software part, the tested code for the problem of processing the pulse input and displaying the analysis result in the form of ECG waveform and heart rate count was successfully burnt on the microcontroller. The output of heart rate count displayed is as shown in figure 13.

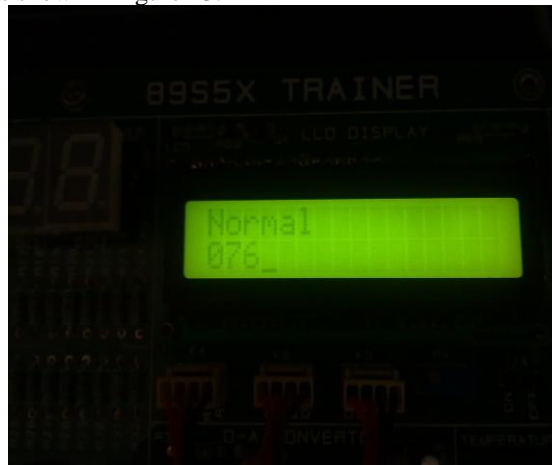

Fig 13: LCD output at normal heart rate

## VI. CONCLUSION AND FUTURE SCOPE

### A. Conclusion:

This paper presents the implementation of an ECG Monitoring and Heart Rate Measurement System involving low cost amplifier, filter components coupled with a sophisticated microcontroller and LCD screen using the available resources in our college.

This project was successfully implemented and the output displayed was an ECG waveform on the CRO and Heart rate is counted by microcontroller for one minute and displayed on LCD.

### B. Future Scope:

- The project can be further developed in future by adding expert system features like speed variations with moving screen, exact heart rate with analysis, displaying 12 lead graphs, and monitoring ECG wave form on PC monitor.
- We can enhance the feature of the project by enabling the transmission of ECG signals through mobiles, signal transmitters or internet.

## ACKNOWLEDGMENT

We would like to convey our sincere thanks to management and supportive staff, HKBK College of Engineering, Bangalore for encouraging us to come up with this project work.





ISSN: 2319-5967

ISO 9001:2008 Certified

International Journal of Engineering Science and Innovative Technology (IJESIT)

Volume 2, Issue 3, May 2013

#### REFERENCES

- [1] Braunwald E. (Editor), Heart Disease: A Textbook of Cardiovascular Medicine, Fifth Edition, p. 108, Philadelphia, W.B. Saunders Co., 1997. ISBN 0-7216-5666-8.
- [2] Van Mieghem, C; Sabbe, M; Knockaert, D (2004). "The clinical value of the ECG in no cardiac conditions" Chest 125(4):1561–76.Doi:10.1378/chest.125.4.1561.PMID 15078775.
- [3] "2005 American Heart Association Guidelines for Cardiopulmonary Resuscitation and Emergency Cardiovascular Care - Part 8: Stabilization of the Patient With Acute Coronary Syndromes." Circulation 2005; 112: IV-89-IV-110.
- [4] A. R. Houghton and D. Gray., "Making sense of the ECG"., Hodder Arnold Publishing's 2003.
- [5] Forerunner 201/301 User Guide, web site: <http://www.grmin.com>.
- [6] Pulsar heart rate monitors, web site: <http://www.heartratemonitor.co.uk>.
- [7] David A. Bell, "Operational amplifiers and linear ICs", 2<sup>nd</sup> Edition, Oxford University Press, 1997.
- [8] Kenneth.J.Ayala,"The 8051 Microcontroller Architecture programming and Applications", 2nd Edition.
- [9] Janicegillispie Mazidi, Muhammad Ali Mazidi,"The 8051Microcontroller and Embedded System", 2nd Edition, Person Education 2009.
- [10] Webster John G., "Medical Instrumentation. Application and Design", 3rd Edition Wiley, 1998.
- [11] Ramakant A. Gayakwad, "Op-amps and linear integrated circuits", 2<sup>nd</sup> Edition Prentice Hall, 2000..
- [12] ECG Measurement System -Chia-Hung Chen, Shi-Gun Pan, Peter Kinget.
- [13] Daniel Paulus / Thomas Meier,"ECG-Amplifier", MB Jass 2009.
- [14] G.M.Patil, K.Subbarao, V.D.Mytri, A.D. Rajkumar, D.N.Reddy and K. "Embedded Microcontroller based Digital Telemonitoring System for ECG", J. Instrum.Soc. India 37(2) 134-149.
- [15] Dr. P. K. Dash, "Electrocardiogram Monitoring", Indian J.Anaesth. 2002; 46 (4): 251-256.
- [16] A. Karilainen, T. Finnberg et. Al... Mobile Patient Monitoring Based on Impedance-Loaded SAW-Sensors. IEEE Transactions on Ultrasonics, Ferroelectrics and Frequency Control. Vol. 51. No. 11. Pp 1464 – 1469.2004.
- [17] Opamp Instrumentation Amplifier" e Circuit Centre 2002. <http://www.ecircuitcenter.com/Circuits/instamp1/instamp1.htm>.
- [18] Lu, M., "The Design and Construction of an ECG Telemetry System", M.S. Thesis,University of Queensland, 1994..
- [19] Jose J.Segura, David Cuesta-Frau, Luis Samblas-Pena Mateo Aboy. "A Microcontroller Based Portable Electro-cardiograph Recorder". IEEE Transaction on biomedical Engineering, 2004:51(9), 1686-1690.
- [20] R.Paradiso, Milior SpA, Smartex s.r.l. "Wearable Health Care System for Vital Signs Monitoring", Proc of the 4th Annual IEEE Conf on Information Technology Applications In Biomedicine, 2004:283-286.
- [21] R.L. Lux, C.R. Smith, R.F. Wyatt, and J.A. Abildskov., " Limited lead selection for estimation of body surface potential maps in electrocardiography". IEEE Transaction Biomedical Eng., 25:270–276, 1978.
- [22] [http://www.biopac.com/Manuals/app\\_pdf/app109.pdf](http://www.biopac.com/Manuals/app_pdf/app109.pdf).
- [23] <http://codesproject.blogspot.in/2008/02/spi-programmer.html>.

#### AUTHOR BIOGRAPHY



**Naazneen M. G:** She completed her B.E in Electronics and Communication Engineering and M.Tech in Digital Electronics. Currently she is working as a Lecturer at HKBK College of Engineering, Bangalore. Her area of interest includes Image Processing, Network Security and Embedded Systems. She has four National Conference papers and one International Journal to her Credit. She is a member of ISTE and IETE.



ISSN: 2319-5967

ISO 9001:2008 Certified

International Journal of Engineering Science and Innovative Technology (IJESIT)

Volume 2, Issue 3, May 2013

	<p><b>Sumaya Fathima:</b> She completed her B.E in Electronics and Communication Engineering and M.Tech in Digital Communication and Networking. Currently she is working as a Lecturer at HKBK College of Engineering, Bangalore. Her area of interest includes Her area of interest includes VLSI, Networking and Embedded System. She has three National Conference papers to her Credit. She is a member of ISTE and IETE.</p>
	<p><b>Syeda Husna Mohammad:</b> She completed her B.E in Electronics and Communication Engineering and M.Tech in Digital Electronics &amp; Communication. Currently she is working as a Senior Lecturer at HKBK College of Engineering, Bangalore. Her area of interest includes VLSI, Image processing, embedded system. She has one National Conference paper and one International Journal to her Credit. She is a member of ISTE and IETE.</p>
	<p><b>Sarah Iram L. Indikar:</b> She completed her B.E in Electronics and Communication Engineering. Currently she is working as a Lecturer at HKBK College of Engineering, Bangalore. Her area of interest includes VLSI, Networking and Embedded System. She has one International Journal to her Credit. She is a member of ISTE and IETE.</p>
	<p><b>Abdul Saleem:</b> He completed his B.E in Medical electronics Engineering and M.Tech in Embedded and VLSI systems. Currently he is working as Senior Lecturer at HKBK College of Engineering, Bangalore. His area of interest includes VLSI and Embedded Systems. He has three National Conference papers and one International Journal to his Credit. He is a member of ISTE and IETE.</p>
	<p><b>Mohamed Jebran:</b> He completed his B.E in Electronics and Communication Engineering and M.Tech in Digital Communication and Networking. Currently he is working as Lecturer at HKBK College of Engineering, Bangalore. His area of interest includes Wireless communication, Antenna design, and image processing and medical electronics. He has three National Conference papers and one International Journal to his Credit. He is a member of ISTE and IETE.</p>