



ISSN: 2319-5967

ISO 9001:2008 Certified

International Journal of Engineering Science and Innovative Technology (IJESIT)

Volume 2, Issue 3, May 2013

VSC - HVDC Transmission System Analysis Using Neural Networks

J Nandana, Pannala Krishna Murthy, Satya Durga

Swarna Bharathi Institute of Science & Technology, Khammam – 507002 A.P., India

Abstract— Confronting with an increasing demand of power, there is a need to explore the most efficient and reliable bulk power transmission system. Rapid development in the field of power electronics devices especially Insulated Gate Bipolar Transistors (IGBTs) has led to the High Voltage Direct Current (HVDC) transmission based on Voltage Source Converters (VSCs). This new innovative technology provides substantial technical and economical advantages for direct applications compared to conventional HVDC transmission system. The VSC based HVDC transmission system mainly consists of two converter stations connected by a DC cable. This paper presents the performance analysis of VCS based HVDC transmission system. In this paper a 75kM long VSC HVDC system is simulated for various faults on the AC side of the receiving station using MATLAB®/SIMULINK. The data has been analyzed and a method is proposed to classify the faults by using back propagation algorithm. The simulated results presented in this paper are in good agreement with the published work.

Index Terms— Voltage Source Converters (VSCs), High Voltage Direct Current (HVDC), fault analysis, back propagation algorithm, neural networks.

I. INTRODUCTION

High voltage direct current (HVDC) transmission is an economic way for long distance bulk power delivery and/or interconnection of asynchronous system with different frequency. HVDC system plays much more important role in power grids due to their huge capacity and capability of long distance transmission [1]. The development of power semiconductor devices, especially IGBT's has led to the transmission of power based on Voltage source converters (VSCs). The VSC based HVDC installation has several advantages compared to conventional HVDC such as, independent control of active and reactive power, dynamic voltage support at the converter bus for enhancing stability possibility to feed to weak AC systems or even passive loads, reversal of power without changing the polarity of dc voltage (advantageous in multi terminal dc system) and no requirements or fast communication between the two converter stations. HVDC light is also called voltage source converter HVDC or VSC HVDC. HVDC light can control both active and reactive power independently without commutation failure in the inverters. Each converter station is composed of a VSC. The amplitude and phase angle of the converter AC output voltage can be controlled simultaneously to achieve rapid, independent control of active and reactive power is bi-directional and continuous across the operating range. For active power balancing, one of the converters operates on dc voltage control and other converter on active power control. When dc line power is zero, the two converters, can function as independent STATCOMs. Each VSC has a minimum of three controllers for regulating active power outputs of individual VSC. It does not require reactive power compensator resulting much smaller equipment size. HVDC light can be applied to the voltage support in the receiver system. It provides inter-connection between two asynchronous power systems, grid connection of large wind farm, undersea power transmission, bidirectional power flow etc., [2].

The basic function of a VSC is to connect the DC voltage of the capacitor into AC voltage. The IGBT can be switched on at any time by appropriate gate voltages. However, one IGBT of a branch can be switched off before to prevent a short circuit of storage capacitor. Reliable storage converter inter lock function will preclude unwanted switching IGBT. Alternating switching the IGBT's of one phase module as shown in Figure 1 successively connects the AC terminals of the VSC to the positive tapping and negative tapping of the DC capacitor [3]. This results in a star stepped AC voltage comprising two voltages levels $+V_{dc}/2$ and $-V_{dc}/2$.

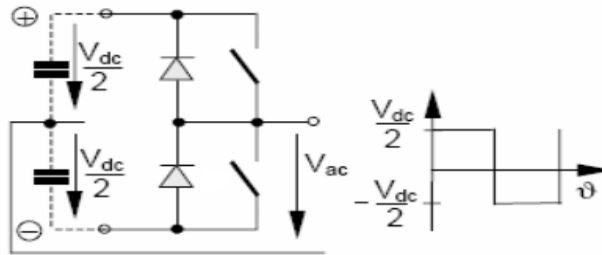

Fig 1. Operational principle of VSC

The VSC based HVDC transmission system mainly consists of two converter stations connected by a dc cable. Usually the magnitude of AC output voltage of converter is controlled by Pulse Width Modulation (PWM) without changing the magnitude of DC voltage. Due to switching frequency, that is considerably higher than the AC system power frequency the wave shape of the converter AC will be controlled to vary sinusoidal. This is achieved by special Pulse Width Modulation (PWM). A three level VSC provides significant better performance regarding the Total Harmonic Distortion (THD).

II. PULSE WIDTH MODULATION (PWM)

A converter is interconnecting two electric networks to transmit electric power from one network to other, each network being coupled to a respective power generator station. The converter, having an AC side and a DC side, includes a bridge of semiconductor switches with gate turn-off capability coupled to a control system to produce a bridge voltage waveform having a fundamental Fourier component at the frequency of the electric network coupled to the AC side of the converter. The control system includes three inputs for receiving reference signals allowing controlling the frequency, the amplitude and the phase angle of the fundamental Fourier component and the alternating voltage of the network coupled to the DC side of the converter [4].

The principle characteristic of VCS-HVDC transmission is its ability to independently control the reactive and real power flow at each of the AC systems to which it is connected, at the Point of Common Coupling (PCC). In constant to line commutated HVDC transmission, the polarity of the DC link voltage remains the same with the DC current being reversed to change the direction of power flow.

III. SIMULATION MODEL

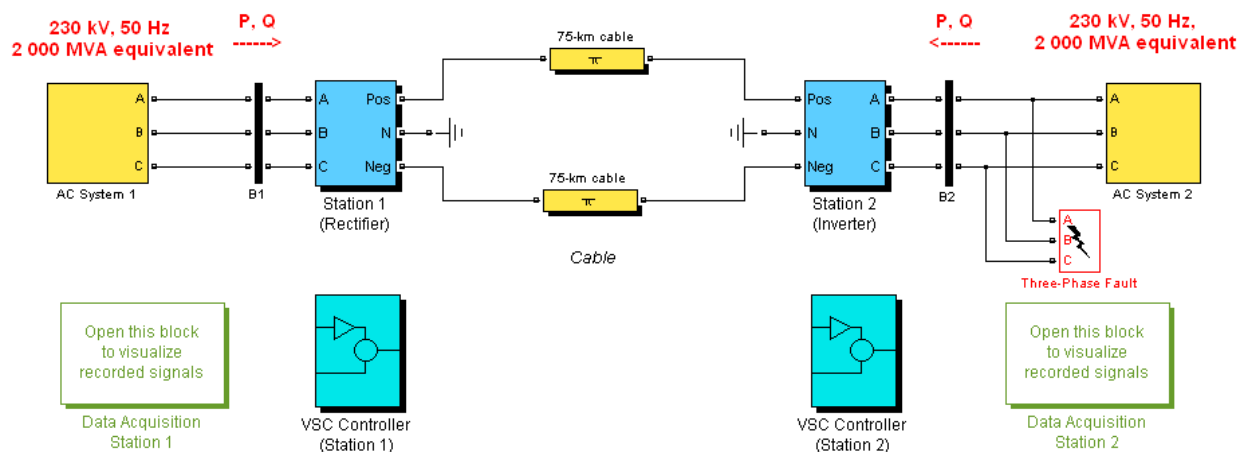

Fig.2. VSC-HVDC Transmission System Model

The 230 kV, 2000 MVA AC system (AC system and AC system 2 subsystems) are modeled by damped L-R equivalents, with an angle of 800 at fundamental frequency (50HZ) and at the third harmonic. The simulation model is as shown in Figure 2. The VSC converters are three-level bridge blocks using close to ideal switching device model of IGBT/diodes. The control capability of IGBTs and its suitability for high frequency switching has



ISSN: 2319-5967

ISO 9001:2008 Certified

International Journal of Engineering Science and Innovative Technology (IJESIT)

Volume 2, Issue 3, May 2013

made this device the better choice over GTO and thyristor. Like all power electronic converters, VSC generate harmonic voltages and currents in the AC and DC systems connected. In a simplified manner, from the AC system a VSC can be considered a harmonic current source connected in parallel to the storage capacitor. This behavior is just opposite to those of conventional line commutated converters.

Harmonics generated depends on the station topology, switching frequency of IGBTs and pulse pattern applied. Using 12 pulse configurations instead of 6 pulse will improve harmonic condition both on AC and DC side. Characteristic AC side harmonics will have the ordinal numbers

$$V_{ac}=12n+1 ; n = 1, 2 \dots \dots \dots (1)$$

Characteristic DC harmonic will have the ordinal numbers

$$V_{dc} =12n; n = 1, 2 \dots \dots \dots (2)$$

All harmonics will be cancelled out under ideal conditions. Due to its inherent harmonic elimination capability the harmonic interface of VSC converter is rather small in comparison to the conventional line commutated converters. However harmonics filters might be necessary on the AC and DC sides depending on the harmonics performance requirements both for AC and DC sides [5]. AC system harmonic impedance, DC line/cable impedance and loss evaluation.

IV. ARTIFICIAL NEURAL NETWORKS

Artificial Neural Networks are being widely used in the classification problems. ANNs are massively parallel interconnected networks of simple adaptive elements and their hierarchical organizations which are intended to interact with the objective of the real world in the same way as the biological counterparts. Neural networks find wide application in parallel distributed processing and real-time environments. Neural networks have considerable advantage over expert system in terms of knowledge acquisition. An important feature of the fault diagnosis using neural networks is that they can interpolate the training patterns to give an appropriate response for cases described by neighboring or noisy input data. For a neural network, if activation and out put functions are chosen, it is completely described by the weights and node thresholds. The training process is the process of finding the weights and thresholds for the network and it is equivalent to find the unknown Input – output relationship. Thus neural networks are appropriate and especially powerful when they are used to find such relationships that are difficult to describe explicitly. Among all the proposed neural network structure, the Feed Forward Neural Network (FFNN) is most popular one [6]. It contains an input layer, an output layer and many hidden layers. Each layer can have many processing nodes or neurons as represented in Figure 3.

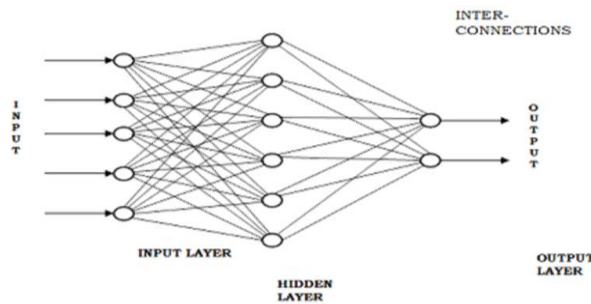

Fig 3. Architecture of a layered feed-forward Neural Network

In order for a neural network to learn certain relationship, data sets describing the relationship must be presented to the net and certain learning rules be applied to the network parameters. In this paper, back propagation learning algorithm is used to train the network. This learning rule is also noted as generalized delta rule. The back propagation training algorithm is an interactive gradient algorithm designed to minimize the mean square error between the actual outputs of a three layer feed forward neural network and the desired output. It was a gradient search technique to minimize a cost function equal to the mean square differences between the desired and actual net outputs. The neural network is trained by initially selecting small random weights and internal thresholds and then presenting all training data repeatedly. Weights are adjusted after every trial using information specifying the appropriate desired fault condition. The BPA propagates error terms to adapt weights from nodes in the output layer to nodes in the hidden and input layer [7].



ISSN: 2319-5967

ISO 9001:2008 Certified

International Journal of Engineering Science and Innovative Technology (IJESIT)

Volume 2, Issue 3, May 2013

The objective is to classify 5 different categories of faults on the HVDC transmission system. The following are the major steps in the process of classification of faults on HVDC system:

- Selection of input/output variables
- Processing of input/outputs.
- structural design of the NN
- fault simulation to generate training and test patterns
- training of the NN, and
- Evaluation of the classifier using unseen test patterns.

V. SIMULATION RESULTS

During no fault the DC line voltage of the bipolar transmission is about 1pu (positive and negative) as shown in Figure 4(a) and the mean DC line voltage of the VCS HVDC transmission system is 1pu as shown in fig Figure 4(b). It is observed that the power transmitted is around -0.8pu. During no fault on the AC side DC line voltage of the bipolar transmission is about 1pu (positive and negative) and the mean DC line voltage of the VCS HVDC transmission system is 1pu. It is observed that the power transmitted is around -0.8pu. During LG fault on AC side of the inverter as shown in Figure 5 active power is about 0.8pu (positive and negative) and the reactive power of the VCS HVDC transmission system is -0.6 pu as. The AC voltage at bus 1 of a phase is zero.

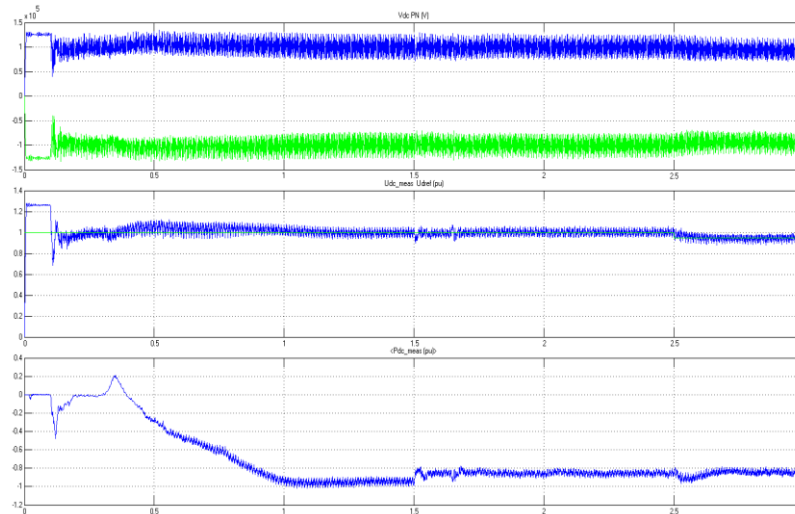

Fig 4. VSC HVDC transmission system without fault condition (a) DC line Voltage; (b) mean DC line voltage; (c) DC power transmitted

During LG fault on AC side of the inverter active power is about 0.8 pu and the reactive power of the VCS HVDC transmission system is -0.6 pu as shown in Figure 5. During LG fault on the AC side DC line voltage of the bipolar transmission is about 1pu (positive and negative) as shown in Figure 6(a) and the mean DC line voltage of the VCS HVDC transmission system is 1pu as shown in Figure 6(b). It is observed that the power transmitted is around -0.8pu. During LL fault on AC side of the inverter active power is about 0.8pu (positive and negative) as shown in Figure 7(a) and the reactive power of the VCS HVDC transmission system is -0.6pu as shown in Figure 7(b). The AC voltage at bus 1 of a phase is zero shown in Figure 7(c). The AC current at bus 1 change in phase sequence is shown in Figure 7(d). During LLG on the AC side DC line voltage of the bipolar transmission is about 1pu (positive and negative) as shown in Figure 8(a) and the mean DC line voltage of the VCS HVDC transmission system is 1.2 pu as shown in Figure 8 (b). It is observed that the power transmitted is varies from -0.8 to -0.2pu. During LLG fault on AC side of the inverter active power is about 0.5pu (and the reactive power of the VCS HVDC transmission system is -0.1pu as shown in Figure 8.



ISSN: 2319-5967

ISO 9001:2008 Certified

International Journal of Engineering Science and Innovative Technology (IJESIT)

Volume 2, Issue 3, May 2013

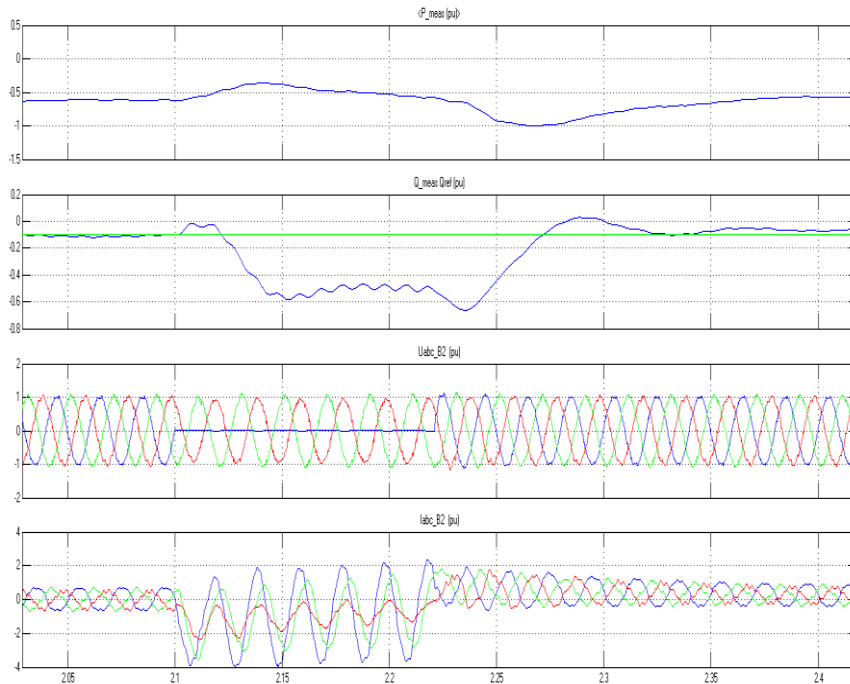

Fig 5 VSC HVDC transmission system During LG fault on the AC side of the inverter (a) active power (b) reactive power (c) ac voltage at bus 1 and (d) ac current at bus 1

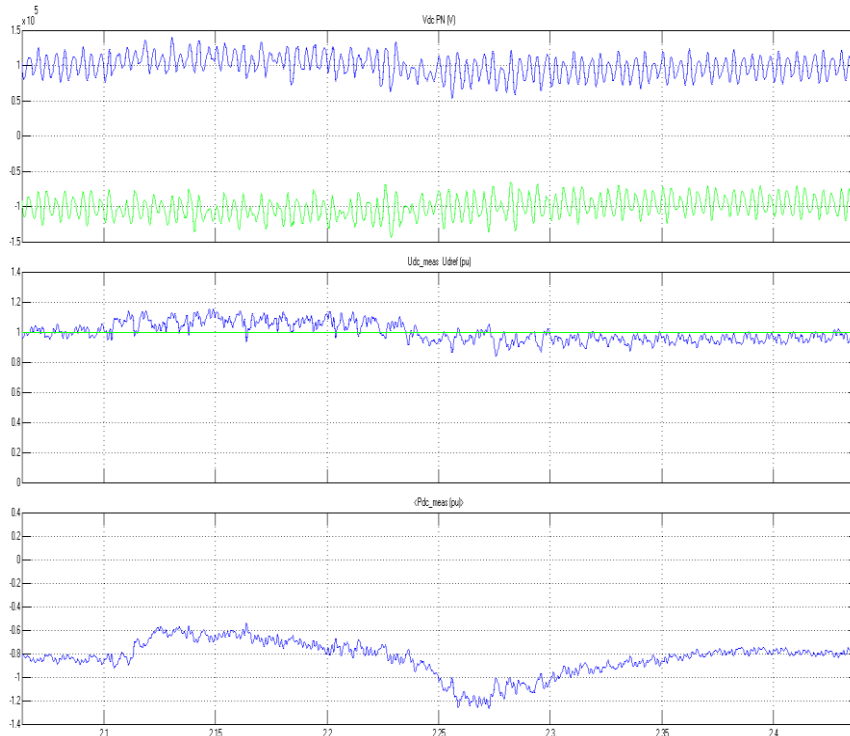

Fig 6 VSC HVDC transmission system During LG fault on the AC side of the inverter (a) DC line Voltage – Positive & Negative; (b) mean DC line voltage; (c) DC power transmitted

During LLG fault on the AC side DC line voltage of the bipolar transmission is about 1pu and the mean DC line voltage of the VCS HVDC transmission system is 1 pu as shown in Figure 9. It is observed that the power transmitted is varies from -0.8pu to -0.2p.u.



ISSN: 2319-5967

ISO 9001:2008 Certified

International Journal of Engineering Science and Innovative Technology (IJESIT)

Volume 2, Issue 3, May 2013

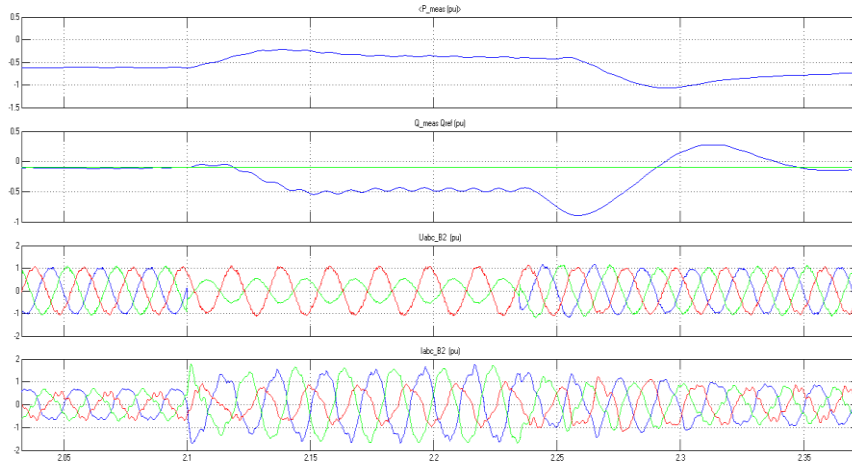

Fig 7 VSC HVDC transmission system During LL fault on the AC side of the inverter (a) active power (b) reactive power (c) ac voltage at bus 1 and (d) ac current at bus 1

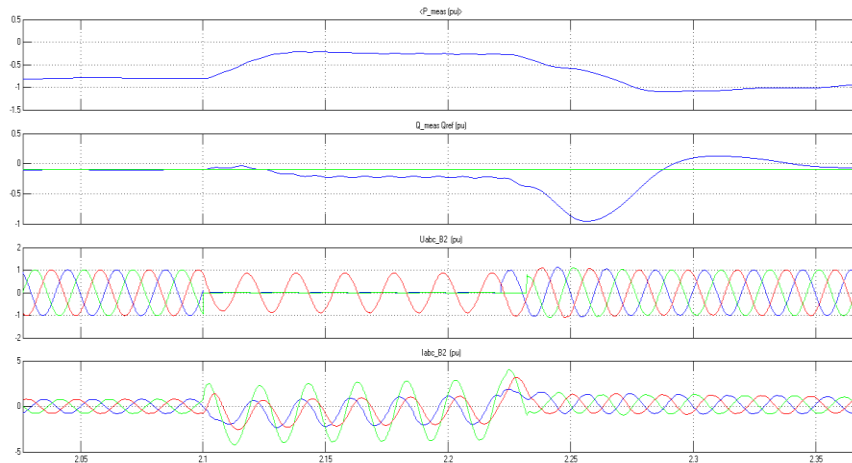

Fig 8 VSC HVDC transmission system During LLG fault on the AC side of the inverter (a) active power (b) reactive power (c) ac voltage at bus 1 and (d) ac current at bus 1

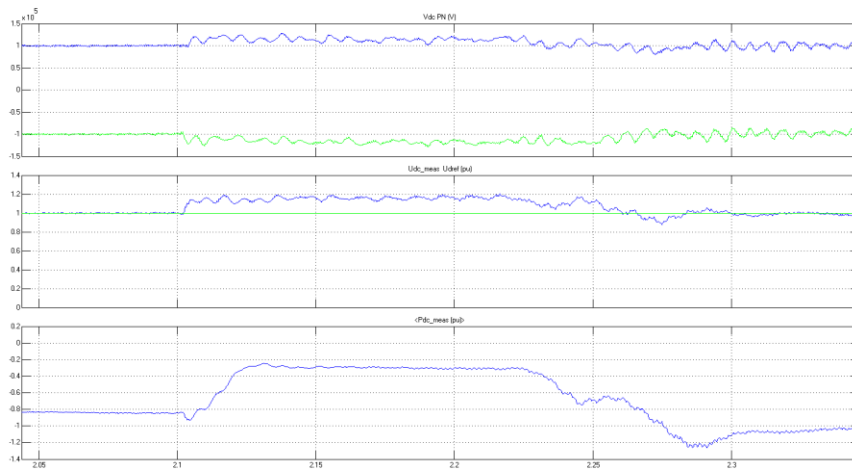

Fig 9 VSC HVDC transmission system During LLG fault on the AC side of the inverter (a) DC line Voltage – Positive & Negative; (b) mean DC line voltage; (c) DC power transmitted



ISSN: 2319-5967

ISO 9001:2008 Certified

International Journal of Engineering Science and Innovative Technology (IJESIT)

Volume 2, Issue 3, May 2013

During LLLG fault on AC side of the inverter active power is about 0 (positive and negative) and the reactive power of the VCS HVDC transmission system is 0.1pu Figure 10.

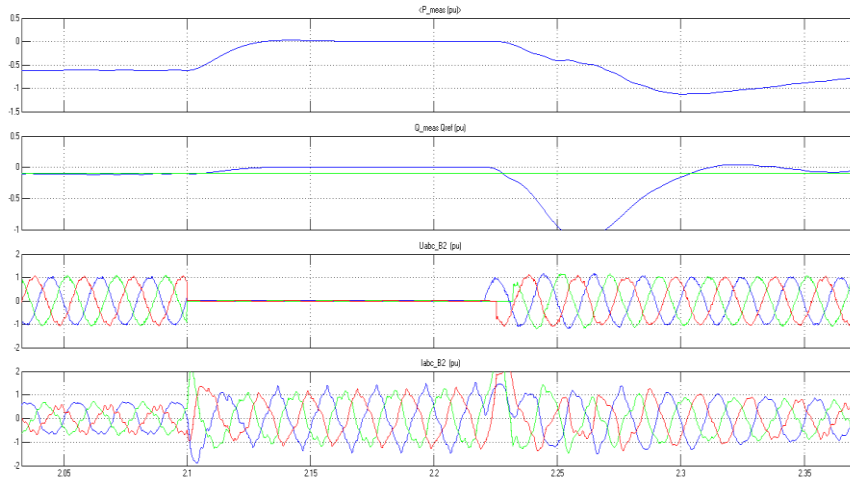

Fig 10 VSC HVDC transmission system During LLLG fault on the AC side of the inverter (a) active power (b) reactive power (c) ac voltage at bus 1 and (d) ac current at bus 1

A. Analysis of faults using Neural Networks:

VSC HVDC system is subject to various faults on the AC side of the inverter and the fault data has been for training and testing. 35 sets of data for various operating conditions of VSC HVDC system has been used for training the back propagation algorithm based on neural network system. 8 sets of data have been used for testing. While training the neural network system the neural network controller took 374 epochs to converge the results are presented in the given Table-I.

TABLE I. ANALYSIS OF FAULTS USING NEURAL NETWORKS

| Fault condition | Test 1 | Test 2 | Test 3 | Test 4 | Test 5 | Test 6 | Test 7 | Test 8 |
|-----------------|--------|--------|--------|--------|--------|--------|--------|--------|
| No fault | Y | Y | Y | Y | Y | Y | Y | Y |
| LG fault | Y | Y | Y | Y | Y | Y | Y | Y |
| LL fault | Y | Y | Y | Y | Y | Y | Y | Y |
| LLG fault | Y | Y | Y | Y | N | Y | Y | Y |
| LLL fault | Y | Y | Y | N | Y | Y | Y | N |

The results obtain after testing the neural networks system are presented. It's observed that around 92.5% of efficiency is achieved in identifying the various faults on the HVDC system.

VI. CONCLUSION

Increasing demand of electrical power and need for bulk efficient electrical power transmission system lead to the development of HVDC transmission system. HVDC transmission system today become one of the best alternative for transmitting bulk power over long distance with very less losses. This paper provided a most efficient method to reduce the harmonics contents in the HVDC transmission system by improving the inverter topology through Selective Harmonic Elimination Technique. A sample system has been designed based on the SHE PWM technique and the model is simulated to assess the performance of the system. The fault data has been analyzed using back propagation algorithm. The neural networks system is used to identify the type of the fault on the AC side of the inverter during various fault conditions. The results presented indicate a better efficiency in identification of type of fault.



ISSN: 2319-5967

ISO 9001:2008 Certified

International Journal of Engineering Science and Innovative Technology (IJESIT)

Volume 2, Issue 3, May 2013

ACKNOWLEDGMENT

The authors would like to thank the Management, the Directors and the members of the Department of Electrical & Electronics Engineering (EEE) of Swarna Bharathi Institute of Science and Technology (SBIT), Khammam for the continued support in executing this work in the Department.

REFERENCES

- [1] N. Flourentzou, V. G. Agelidis, and G. D. Demetriades, "VSC-based HVDC power transmission systems: an overview," IEEE trans. Power Electronics, Mar. 2009, Vol. 24, No. 3, pp. 592–602.
- [2] A. A. Edris, S. Zelingher, I. Gyugyi, and I. J. Kovalsky, "Squeezing More Power From The Grid," IEEE power eng. Rev., Jun. 2002, Vol. 22, No. 6, pp. 4–6.
- [3] G. Asplund, "Application Of HVDC Light To Power System Enhancement," In proc. IEEE power eng. Soc. Winter meeting, Singapore, Jan. 2000, Vol. 4, pp. 2498–2503.
- [4] P. N. Enjeti and W. Shireen, "A New Technique To Reject DC-Link Voltage Ripple For Inverters Operating On Programmed PWM Waveforms," IEEE Trans. Power electronics 1992, Vol. 7, No. 1, pp. 171–180.
- [5] Nikolas Flourentzou and Vassilios. G. Agelidis, "Optimized Modulation for AC–DC Harmonic Immunity in VSC HVDC Transmission", IEEE Trans. Power Delivery, July 2010, Vol. 25, No. 3, pp. 1713-1720.
- [6] P. Krishna Murthy, J. Amarnath, S. Kamakshaiah and B. P. Singh. 2009. "HVDC transmission system fault diagnosis and location using Artificial Neural Networks". International Conference on Energy and Environment, Enviro Energy. March 19-21. pp. 847-851.
- [7] C.Chih-Liang and R.S.Nutter, "An Extended Back-Propagation Learning Algorithm by Using Heterogeneous Processing Units", International Joint Conference on Neural Networks (IJCNN'92), June 7-11, 1992.

AUTHOR BIOGRAPHY



J. Nandana received her B. Tech degree from JNTUH, Hyderabad in 2007. She has completed her M.Tech in Power Electronics from JNTUH, in 2012. She is at present working as Assistant professor in Swarna Bharathi Institute of Science & Technology. She is also a life member of the Indian Society of Technical Education. Her areas of interests include HVDC, power electronic devices, control systems and power electronics applications in control systems and power systems.



Dr. Pannala Krishna Murthy has secured his B. Tech from SSGMCE- Shegoan. He obtained his masters degree from JNTU College of Engineering, Kukatpally, and Hyderabad. He received Doctor of Philosophy in Electrical Engineering for his work titled "Analysis & Identification of HVDC system faults using Wavelet Transforms" from JNTU, Hyderabad in 2010. He got more than 26 Technical Publications to his credit at National / International level. He is supervising 5 Ph.D. scholars registered with various universities of Andhra Pradesh. He guided more than 30 UG projects and guided 10 PG projects. At present he is working on the research problems of HVDC system fault analysis using wavelet transforms.



Satya Durga received her M.Sc. Degree from Acharya Nagarjuna University, Guntur in the year 2003 and pursuing M.Tech in Computer Science & Engineering from JNTUH, Hyderabad. Her areas of research include Data Mining, Artificial Intelligence and Artificial Neural Networks.