



ISSN: 2319-5967

ISO 9001:2008 Certified

International Journal of Engineering Science and Innovative Technology (IJESIT)

Volume 2, Issue 2, March 2013

# Testing the Effect of Negative Electric Discharge on Fog

V. S. Sawant

Dept. of Physics, Y. C. Institute of Science. Satara-415001, Maharashtra, India

*Abstract - This study investigates the possibility of reduction of fog collected in the closed container with the help of negative electric discharge (Negative Air Ions). For construction of negative electric discharge a high voltage power supply is designed and developed indigenously. The high output voltage is developed by using isolation transformer, autotransformer, and high voltage neon transformer and it is converted into DC voltage by using Wheatstone bridge circuit and high voltage capacitor. Formation of negative corona and voltage-current characteristics of corona ionization was studied. By adjusting -9 kV electric voltage to discharge electrode, the performance of this circuit was tested for removal of fog, generated by using ultrasonic water fogger collected in closed glass container. Various runs were carried out. The light intensity was measured for each run as a function of time, in presence and absence of negative air ions generated by the discharge electrode of the designed ion generator. After operating this device continuously for 6 minutes, 93% to 98% of the aerosol particles were removed from container in addition to the natural decay effect.*

**Index Terms - Aerosol removal, Electric discharge, Fog, High voltage, Ion generator.**

## I. INTRODUCTION

Artificial ionized air is commonly used for reducing particle concentrations in indoor environment. Reference [1] reported that negative air ions (NAIs) reduce aerosol particles, airborne microbes, odors and volatile organic compounds (VOCs) in indoor air. The particle removing mechanisms by NAI is due to particle charging by emitted ions and electro migration which increases migration velocity of particles [2]-[4]. Several studies have been conducted for particle removing efficiency using ionic cleaners to remove particles from the air [2],[5]-[7]. The high voltage used for ion generation produces Ozone above threshold voltage of 16000 volts. Hence precaution is to be taken to avoid Ozone production which is having negative effect on plants and animals. The ion emission has been tested by several investigators for its ability to reduce the indoor aerosol concentration [5],[8]-[14].

Combustion of firewood, cigarette, tobacco, mosquito repellent coil, petrol, oil fumes etc leads to air pollution in the form of various gases and smoke particles, which are composed of various chemical components. Incomplete combustion results in the formation of polycyclic aromatic hydrocarbons (PAHs) and other chemical compositions [15]-[17]. PAHs include hundreds of compounds that are carcinogenic, especially those containing four to six aromatic rings. This includes Benz (a, h) anthracene, chrysene and benzo (a, e) pyrene. Workers who are exposed to PHAs may develop cancer and experience other negative health effects [18]-[21]. Removal of the atmospheric pollutants such as suspended particle, pollutant gases such as CO, NO<sub>x</sub> and Volatile organic compounds is urgent need of the future to control global warming and Ozone production in troposphere. Ozone in troposphere levels is highly poisonous for plants and animals. The Oxygen ion production using corona discharge is powerful tool for removing effect of above pollutants along with removing suspended biological species. The laboratory studies are urgently required for using this important tool in open air. In this paper we present results on a series of experiments on fog and how it is removed by using negative air ion/electric discharge.

## II. METHODOLOGY

### A. Design & Construction

Schematic layout of the high voltage power supply used in negative electric discharge (Ion Generator) is shown in "Fig.1". The ac mains supply is connected to an isolation transformer, with 1:1 turn's ratio. This transformer isolates the high voltage side from the line. The output of isolation transformer is connected to a variable autotransformer that supplies the input to neon transformer. The output of the neon transformer (variable output of 0-15 kV) is connected to a bridge rectifier configuration, containing four arms of high voltage diode assemblies. Total 52 diodes are used and each arm consists of 13 high voltage diodes. High voltage epoxy/resin combination is used surrounding to the diode chain and resistors to avoid shorting of components due to high voltage in the system during any weather condition. The rectified output is filtered and stored in a large 1  $\mu$ F capacitor. The voltage across the capacitor is measured with a high resistance voltage divider with 100:1 input

to output ratio, by a high input impedance digital voltmeter. The diode terminals and connections have covered with a thick layer of silicon sealant to prevent arcing or corona discharge. The rectified output is filtered and stored in a large capacitor. The capacitor used for the power supply circuit has a rating of  $1 \mu\text{F} \pm 10\%$  at 50 kV dc. High voltage capacitors are bigger in size (13in x 6in x 22in, L x B x H) so that the dielectric medium separating the plates is thick enough to hold the increased potential. The voltage across the capacitor is measured with a high resistance voltage divider with 100:1 input to output ratio by a high input impedance digital voltmeter. All high voltage components are mounted on one cm thick acrylic sheet; Teflon and PVC are used to avoid arcing at different places. Short circuit tripping switch is used. All switches, plugs, meters are mounted on non-conducting polycarbonate sheet.

The diodes in the rectifier have a PIV of 120 kV, so that neon transformer of any rating can be safely used in the circuit. Thus a 15 kV, 450VA transformer will deliver a maximum dc voltage of about 21 kV and a maximum possible current flow of 30 mA, after the voltage drop across the diodes have been taken into account. High voltage power supply is designed to achieve any polarity of the output.

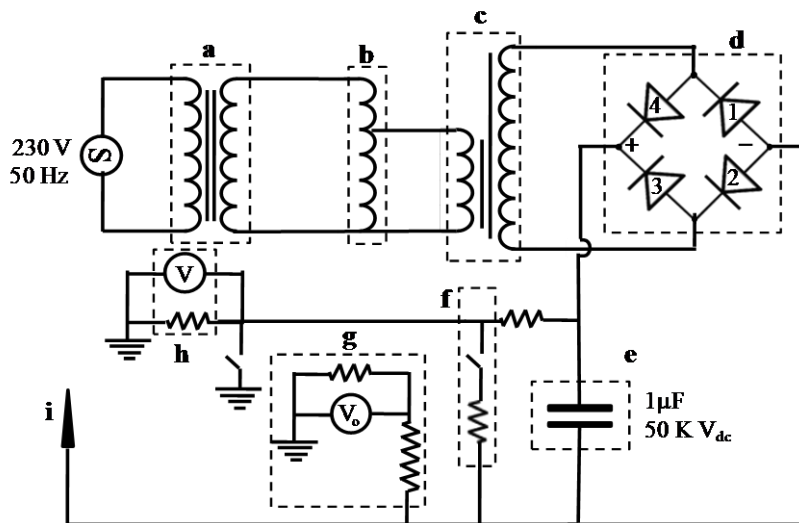

Fig.1. Schematic layout of the power supply a) isolation transformer b) autotransformer c) neon transformer d) bridge rectifier e) high voltage capacitor f) capacitor discharge system g) high voltage measurement system h) current measurement system i) discharge electrode

### B. Experimental procedure and Testing

Block diagram of experimental set up is as shown in “Fig.2”. The experiment was carried out in a dark room. For this an unventilated glass container of size  $72 \text{ cm}^3$  ( $L \times W \times H = 60\text{cm} \times 30\text{cm} \times 40\text{cm}$ ) is used. A Helium-Neon Laser of 2mW, 633 nm wavelength light source was used. Visibility was measured in terms of light intensity using light meter (lux) model LX – 101A of Lutron. The detector and other electronic equipments were placed at the other end of chamber. Fog was generated by using Ultrasonic water fogger with 230 V adaptor, Teflon coated disc of MainLand Mart Corp. EL mount. CA 91732, U. S. A. The light emitted by the source enters the experimental container filled with smoke. Initial light intensity was recorded before and after concentration of fog in the glass container. Light intensity was measured after every 15 second time interval. The discharge electrode of the negative electric discharge placed inside the container was switched on at minimum light intensity. More than four runs were carried out for fog as a function of time in presence and absence of negative air ions. The glass container, cleaned by using soap and water, was used for each run. Qualitative record of corona formation result was tested shown in Table I For the negative potential; there was no corona visible up to 9.5 kV. There was a hissing sound and smell of ozone in the air at lower voltages. At 9.5 kV, one glowing spot of corona was visible on the sharp edge of the discharge electrode. As the voltage was increased, two corona spots became visible on the sharp edge at 10 kV. At 11 kV, there were four corona spots visible. At a little over 11.5 kV, a loud arc shot across the electrode to the ground. The corona is seen as bluish-white spots on the tip of the sharp edge of the electrode. For the tests with the electrode made positive with respect to the ground, there was strong hissing sound and smell of ozone in the air; however, there were no visible corona up till the arcing at about 10 kV. It is important to keep the HV level high enough to generate



ISSN: 2319-5967

ISO 9001:2008 Certified

International Journal of Engineering Science and Innovative Technology (IJESIT)

Volume 2, Issue 2, March 2013

sufficient ion current but low enough to prevent the production of ozone (which can be dangerous for people who suffer respiratory difficulties).

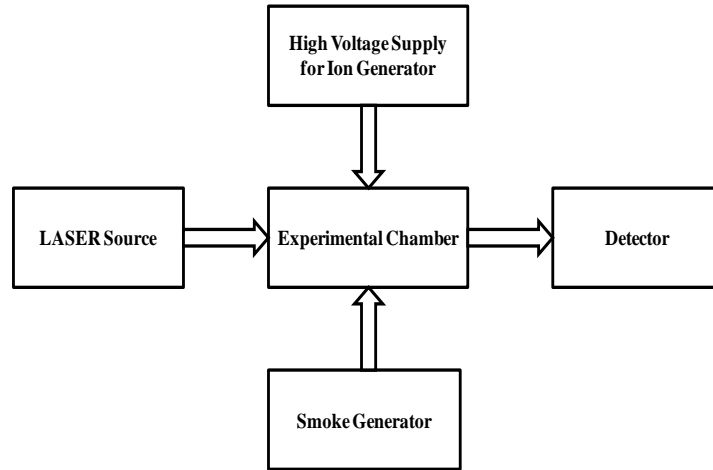

Fig. 2. Block diagram of experimental setup

Table I Results of Corona Formation

Negative Corona		Positive Corona	
Voltage	Effects	Voltage	Effects
9000V	Nil	4500V	Spots of corona
9550V	One corona spot	6000V	Spots of corona
10000V	Two corona spots, hissing sound.	7000V	Spots of corona
10570V	Two corona spots, hissing sound.	8000V	Spots of corona
11040V	Four corona spots, Strong hissing.	9000V	Spots of corona
11555V	Loud Arc, Power supply cut off	10035V	Loud Arc, power supply cut off.

From the above results, it is felt desirable to adjust -9 kV electric voltage to discharge electrode to test the performance of this circuit for removal of fog collected in closed glass container.

**C. Data Analysis**

The experimental data was analyzed by using Beer – Lambert’s Law

$$I = I_0 \exp(-\alpha m) \tag{1}$$

Where,  $I_0$  - incident light intensity,  $I$  - observed light intensity,  $m$  - number of particles and  $\alpha$  - absorbance or scattering cross section of fog / smoke.

The natural decay of particle concentration was determined as a base line to test for each particulate matter. Prior to the test, particles of different substrates were generated in the chamber. Then the particle concentration decay with NAI was determined. For each particulate matter (Pm), two concentration decay curves were obtained: the natural decay i.e. when the NAI was ‘off’ [ $C_{Natural}(Pm, t)$ ], and the one with the NAI ‘on’ [ $C_{NAI}(Pm, t)$ ]. [7]

The particle removal efficiency was determined as follows

$$\text{Particle removal efficiency} = \frac{C_{Natural}(Pm, t = 0) - C_{NAI}(Pm, t)}{C_{Natural}(Pm, t = 0)} \times 100\% \tag{2}$$



ISSN: 2319-5967

ISO 9001:2008 Certified

International Journal of Engineering Science and Innovative Technology (IJESIT)

Volume 2, Issue 2, March 2013

### III. RESULTS AND DISCUSSION

“Fig.3” shows particle concentration decay versus time with natural decay and NAI application for fog. The results in fig. 4 reveal that the reduction in particle concentration when NAI was applied exceeded that associated with natural decay. The natural decay of fog is high as compared to that of smoke. The order of particle concentration decay was **natural decay of smoke < natural decay of fog < fog decay with NAI application < smoke decay with NAI application**. The experimental data proved that the order of particle concentration decay was quite different for all particulate matter. The particle concentration with respect to time shows that the smoke particle concentration reduces fast as compared to other fog sample.

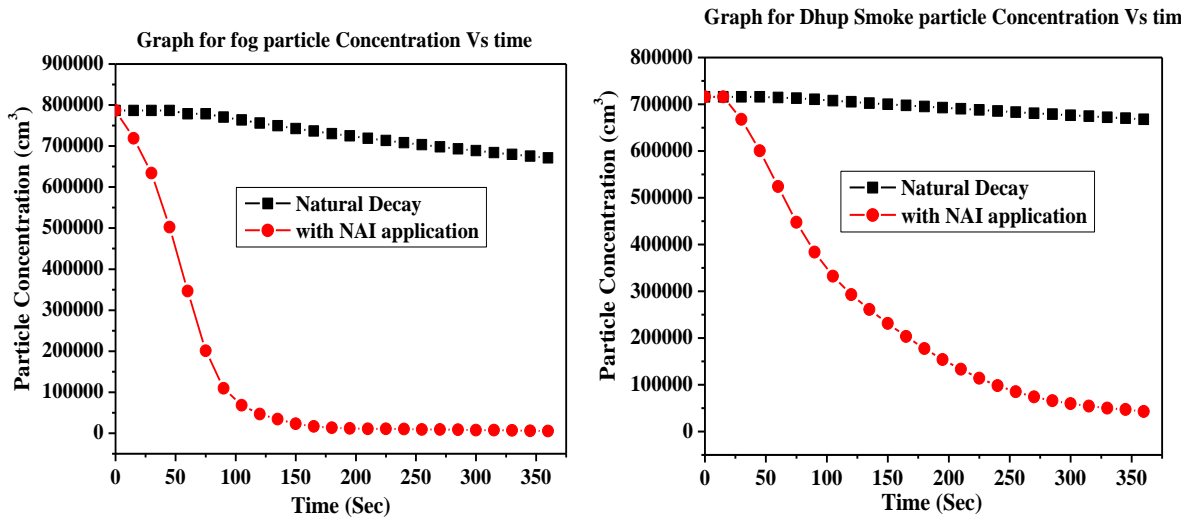

Fig. 3. : Particle concentration decay versus time with natural decay and NAI application for fog.

Fig. 4” shows particle removal efficiency versus time with natural decay and NAI application for mosquito coil smoke and petrol smoke in calm air. The particle removing efficiency is obtained by subtracting the natural decay from the observed value. Mosquito coil smoke natural decay is almost high as compared to natural decay of petrol smoke.

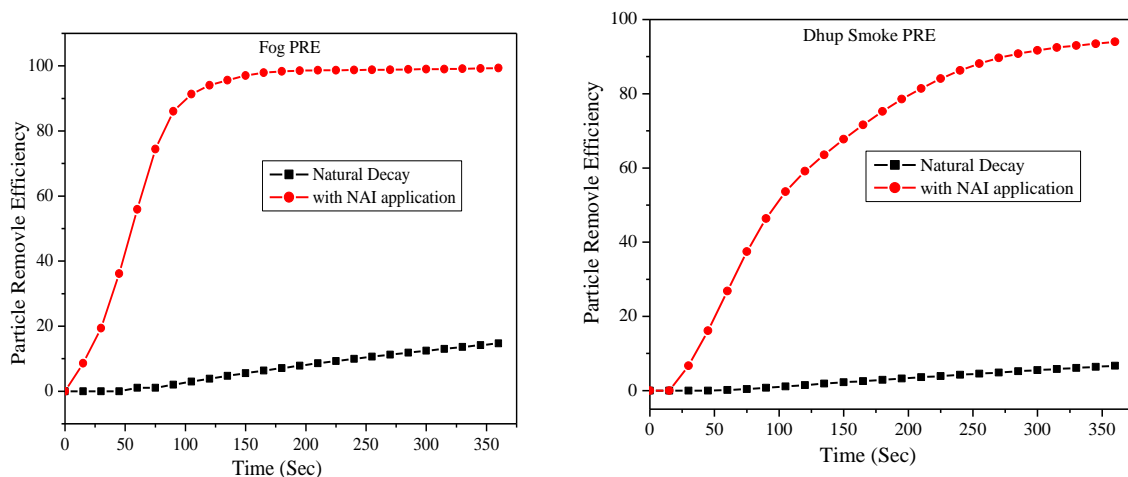

Fig. 4.: PRE versus time with natural decay and NAI application for fog and smoke.

### IV. CONCLUSION

An Ion generator is designed and developed indigenously. For negative corona tests, corona was visible at a lower voltage as compared to positive corona. In this study, we concluded that the negative electric discharge can remove the aerosol pollutants such as fog in closed chamber. The particles are charged primarily by the



ISSN: 2319-5967

ISO 9001:2008 Certified

International Journal of Engineering Science and Innovative Technology (IJESIT)

Volume 2, Issue 2, March 2013

diffusion charging mechanism. The particle removal depends on the ion emission rate and the time of emission. The rate of change of particle removal efficiency is highest for fog as compared to smoke. Hence in future we wish to design different capacity ion generators for removal of fog from the atmosphere. An Ion generator will be an efficient tool for controlling air pollution.

#### ACKNOWLEDGMENT

The authors are thankful to Dr. B. N. Goswamy Director, Indian Institute of Tropical Meteorology, Pune and Dr. A. S. Burungale Principal, Y.C. Institute of Science, Satara for his encouragement and support during this work.

#### REFERENCES

- [1] Daniels, S.L. On the Ionization of Air for Removal of Noxious Effluvia. IEEE Trans. Plasma Sci. 30, 1471–1481, 2002.
- [2] Lee, B.U., Yermakov, M. and Grinshpun, S.A. Removal of Fine and Ultrafine Particles from Indoor Air Environments by the Unipolar Ion Emission. Atmos. Environ. 38, 4815–4823, 2002.
- [3] Wu, C.C., Lee, G.W.M., Cheng, P., Yang, S. and Yu, K.P. Effect of Wall Surface Materials on Deposition of Particles with the Aid of Negative Air Ions. J. Aerosol Sci. 37, 616–630, 2005.
- [4] Mayya.Y.S., Sapra, B.K., Khan, A. and Sunny, F. Aerosol removal by unipolar ionization in indoor environments. J. Aerosol Sci., 35, 923-941, 2004.
- [5] Grabarczyk, Z. Effectiveness of indoor air cleaning with corona ionizers. Journal of Electrostatics, 51–52, 278–283, 2001.
- [6] Grinshpun.S.A., Mainelis.G.,Reponen.T.,Willeke.K.,Trunov.m.A.and Adhikaty.A. Effect of wearable ionizers on the concentration of respirable airborne particles and Microorganisms. Proceedings of the European Aerosol Conference, Leipzig, germany, j. aerosol Sci., 32 (Suppl. 1), S335-S336, 2001.
- [7] Grinshpun, S.A., Mainelis, G., Trunov, M., Adhikari, A.,Reponen, T. and Willeke, K. Evaluation of Ionic Air Purifiers for reducing an Aerosol Exposure in Confined Indoor Spaces. Indoor Air , 15, 235–245, 2005.
- [8] Bigu, J. On the effects of a negative ion-generator and a mixing fan on the plate-out of radon decay products in a radon box. Health Physics, 44(3), 259–266, 1983.
- [9] Bohgard, M., & Eklund, P. Effect of an ionizer on sub-micron particles in indoor air. Journal of Aerosol Science, 29, S1313–S1314, 1998.
- [10] Harrison, R.G. Ionisers and electrical aerosol removal, Proceedings of 10<sup>th</sup> Annual Conference, The Aerosol Society, Swansea, UK, 38-40. J. Aerosol Sci., 27, S191-S192, 1996.
- [11] Hopke, P. K., Montassier, N., & Wasiolek, P. Evaluation of the effectiveness of several air cleaners for reducing the hazard from indoor radon progeny. Aerosol Science and Technology, 19, 268–278, 1993.
- [12] Sawant, V.S., Jadhav, D.B., “Laboratory Experiments on Aerosol Removal by Negative Air Ions” in Inter. Conf. on Envir. Science and Technology IPCBEE vol. 30,pp. 63-67, 2012.
- [13] Sawant, V.S., Meena, G.S. Jadhav, D.B., “Effect of Negative Air Ions on Fog and Smoke” Inter. J. Aerosol and Air Quality Research, 12, 1007-1015, 2012.
- [14] Li, C.-S., & Hopke, P. K. Efficacy of air cleaning systems in controlling indoor radon decay products. Health Physics, 61, 785–797, 1991.
- [15] Furuuchi. M., Tekasakul. P., Murase. T., Otani. Y., Tekasakul. S. and Bai. Y. Characteristic of particulates emitted from rubber-wood burning. J. Ecotechnol. Res. 12, 135-139, 2006.
- [16] Bai. Y., Furuuchi, m., Tekasakul. P., Tekasakul. S., Choosong. T., Aizawa. M., Hata. M. and Otani. Y. Application of soft X-rays in the decomposition of Polycyclic Aromatic Hydrocarbons (PAHs) in smoke particles from biomass fuel burning. Aerosol Air Qual. Res. 7, 79-94. 2007.
- [17] Tekasakul. P., Furuuchi. M., Tekasakul. S., Chomane. J. and Otani. Y. Characteristic of PAHs in particulates in atmospheric environment of the city of Hat Yai, Thailand and relation with rubber-wood burning in rubber sheet production. Aerosol Air Qual. Res. 8, 265-278, 2008.
- [18] Kogevinas, M., sala, M., Boffetta, P., Kazerouni, N., Kromhout, H. and Hoar-zahm, S. Cancer Risk in the Rubber Industry: A Review of Recent Epidemiological Evidence. Occup. Environ. Med. 55; 1-12, 1998.



ISSN: 2319-5967

ISO 9001:2008 Certified

**International Journal of Engineering Science and Innovative Technology (IJESIT)**

**Volume 2, Issue 2, March 2013**

- [19] Fracasso, M.E., Franceschetti, P., Mossini, E., Tieghi, S., Perbellini, L. and Romeo, L.. Exposure to Mutagenic Airborne Particulate in a Rubber Manufacturing Plant. *Mutat. Res.* 441: 43-51, 1999.
- [20] Golka, K., Wiese, A., Assennato, G. and Bolt, H.M. Occupational Exposure and Urological Cancer. *World J. Urol.* 21: 382-391, 2004.
- [21] Parent, M., Siemiatycki, J. and Fritschi, L. Workplace Exposures and Oesophageal Cancer. *Occup. Environ. Med.* 57: 325-334, 2005.



Mr. Vijaysinh Sambhajirao Sawant, Place of birth- Koyananagar, 10<sup>th</sup> January 1962, Education- M.Sc. (Physics) from Department of Physics, University Of Pune, Maharashtra, India. Working Field – Air Ion Generator, Air Pollution, Fog and Smoke Dispersion. Job Title - Associate professor at Department of Physics, Yashvantrao Chavan Institute Of Science, Satara, Maharashtra, India, 415001. He has been preparing Ph.D. thesis at Indian Institute Of Tropical Meteorology and University of Pune, Pune, India. Publications - 1) V.S.Sawant & D.B. Jadhav, “Laboratory Experiment on Aerosol Removal by Negative Air Ions”, in 3<sup>rd</sup> International conference on environmental Science And Technology-ICEST2012. 2) V.S.Sawant & D.B. Jadhav, “Effect of Negative Air Ions on Fog and Smoke”, in International Journal Aerosol and Air Quality Research.